

2

Gate Valves

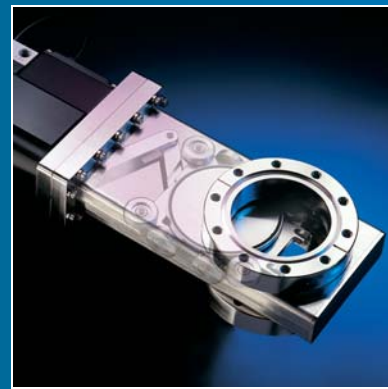

Gate Valves

Introduction	164
Options Guide	164
Specifications	166

Circular Gate Valves

5/8" Ports	168
1-1/2" Ports	170
2" Ports	172
2-1/2" Ports	174
3" Ports	176
4" Ports	178
5" Ports	180
6" Ports	182
8" Ports	184
10" Ports	186
12" Ports	188

Rectangular Gate Valves

SEMI / MESC High Vacuum Series	190
C-Loc® High Vacuum Series	192

Angle & Inline, All-Metal, Leak & Butterfly **195**



In the simplest of terms, vacuum gate valves are devices that regulate the flow of gases, fluids or materials through a structure or aperture by opening, closing or obstructing a port or passageway. Gate valve assemblies consist of three key components: an actuator, a carriage/gate and a valve body. The actuator provides the power to position or transport the valve's carriage/gate. The actuator is attached to the valve's body via a rectangular bonnet flange. The gate closes or opens one of the valve's body ports. The valve body is a vacuum tight chamber that is screwed, flanged or welded into a larger vacuum vessel or system. It is worth noting that reliable vacuum valves were not commercially available until the late 1940s with the advent of O-ring elastomer seals. The elastomer O-ring was developed during WWII for use in aircraft hydraulic systems, and was soon thereafter adopted by the vacuum community as the standard means

of making vacuum seals. Prior to this it was common practice, even in large research establishments, to upgrade general service valves for vacuum use by winding actuator shaft gaskets from string soaked in an Apiezon grease. MDC stainless steel vacuum gate valves incorporate patented C-Loc® and Uni-Loc™ gate valve locking mechanisms. No contact is made between a valve's body and the locking mechanism, a feature which markedly decreases vibration and insures smooth valve operation. MDC gate valves require about half the number of moving parts found in comparable competitor valves. This reduction in moving components minimizes wear and particulate generation which in turn provides valves of superior performance and reliability. The valves' low outgassing characteristics can be attributed to a fusion welded 300 series stainless steel body, welded AM-350 stainless steel nesting bellows as well as small cross-section O-rings and the elimination of blind internal cavities. MDC circular gate valves are offered in various sizes ranging from .625" to 12" port diameters. Standard port mounts include: Del-Seal™ CF metal seal flanges, which are recommended for ultrahigh vacuum service; ISO Kwik-Flange™ and ISO Large-Flange™ fast make and break elastomer sealed flanges, ideal for high vacuum applications requiring frequent assembly and disassembly; and ANSI ASA elastomer seal port flanges for use in high vacuum applications where ANSI standards are specified. Gate valve actuation is available in both manual and electropneumatic configurations. Custom designed valves are available on request.

All dimensions in this catalog are given in inches unless specified otherwise.

Gate Valve Standard Features

- UHV and HV series
- Ports with circular or rect angular apertures
- Del-Seal™ CF, ISO Kwik-Flange™, ISO Large-Flange™ or ANSI ASA port flanges
- Manual and Electropneumatic actuators
- Patented C-Loc® and Uni-Loc™ locking mechanism
- 120VAC air control solenoid valve (Circular gate valves)
- 24VDC air control solenoid valve (Rectangular gate valves)
- OFE copper metal and FKM / FPM fluoroelastomer elastomer bonnet seals
- Welded bellows actuator seal
- TIG welded internal body joints
- Electropolished interior and exterior surfaces
- Dry film lubricated bearings

Gate Valve Optional Features

- Modular Electromechanical position indicators
- Air control solenoid valves for 240VAC and 24VDC service
- Valve body roughing ports
- High temperature 250°C Kalrez® elastomer gate seal

Mechanical Position Indicator Option -01



MDC circular C-Loc® gate valves can be fitted with optional high precision, modular mechanical position indicators (MPI). This new MPI system consists of two single pole double throw micro switches fitted with integral hinged lever and roller actuators. Each micro switch is wired in a normally open position. Normally closed switches are available on request, and easily modified by reversing standard factory wiring. Precise positioning of each micro switch is possible by a patented vernier mechanism found only on MDC gate valves. MPI connections are made via industry standard seven pin circular threaded connectors supplied with mating female cable connectors. All pneumatic valves include solenoids pre-wired through MPI connector box.

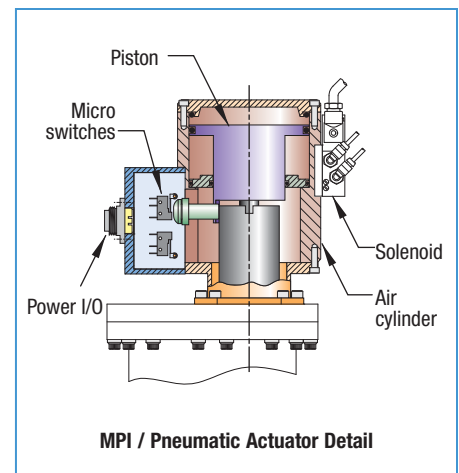

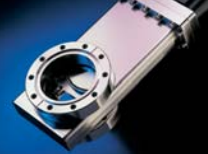

Air Control Solenoid Valve Option -03 and -09



MDC circular gate valves fitted with standard electropneumatic actuators are equipped with Humphrey 410 series 120VAC 50/60Hz air control solenoid valves. AC/DC power consumption is 4.0 watts. Optional 24VDC or 240VAC solenoid valves are available on request. All solenoid valves are fitted with DIN type connectors that conform to international standards. DIN connectors provide simplicity, convenience and fast, easy electrical installation. Solenoid valves come standard with push button/spring return manual override. Manual override is located at top of

solenoid and identified by a prominent red push button. Solenoid valves are designed for use with compressed air from 0 to 100psig. Air should be clean and uncontaminated. When in doubt, install a filter with filtering capacity of 40 microns. Periodically remove and clean or replace filter element. All solenoid electrical leads are pre-wired to MPI box connector.

Caution: Check voltage label on solenoid before connecting power. Do not separate coil portion (black) from body (aluminum).

Roughing Port Option -04, -05 and -06

With the exception of the .625 inch gate valve, all valves can be fitted with roughing ports. Valves with Del-Seal™ CF and ANSI ASA port flanges are supplied with Del-Seal™ CF roughing port flanges. All Del-Seal™ CF roughing ports are tapped. Valves with metric port flanges have Del-Seal™ CF roughing port flanges with metric tapped holes. Gate valves fitted with ISO Kwik and ISO Large port flanges are supplied with ISO Kwik roughing port flanges. Roughing ports will be installed on the side opposite the

gate seal (the carriage side of the valve). Although the location of the roughing port does not affect its function, the positioning of the gate is important. A roughing port provides a path to a vacuum chamber through the gate valve body. With the gate closed, the valve body and chamber may be evacuated by a vacuum roughing pump.

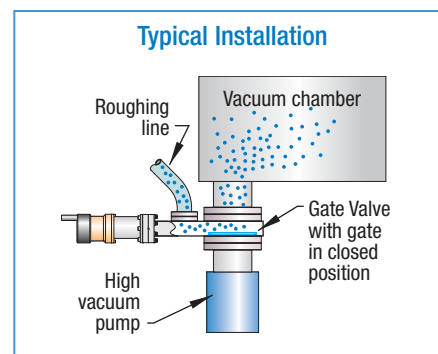

Standard gate valve roughing ports include:

Option-04	1.5" to 3.0" valves	.75" port	1.33 Del-Seal™ CF or ISO-NW16 Kwik-Flange™
Option-05	4.0" to 8.0" valves	1.5" port	2.75 Del-Seal™ CF or ISO-NW40 Kwik-Flange™
Option-06	10" and 12" valves	2.0" port	3.37 Del-Seal™ CF or ISO-NW50 Kwik-Flange™

High Temperature Gate Seal Option -11

Gate valves are supplied standard with FKM / FPM fluoroelastomer gate seals. UHV series valves, which have metal sealed bonnet flanges, can be ordered with the high temperature Kalrez® compound 4079 gate seal gasket option. Kalrez® compound 4079 O-rings are suitable for vacuum bakeout to 250°C (with gate in an open position). Kalrez®

compound 4079 offers excellent chemical resistance and good mechanical properties. When compared to FKM/FPM elastomers, Kalrez® has lower outgassing characteristics for any given temperature from ambient to 250°C. Other special seal materials may be discussed with the MDC technical sales engineers.



- When ordering Gate Valve Options, please add the option number(s) to the end of the desired UHV or HV Series Gate Valve Part Number



CIRCULAR GATE VALVES

Specifications

Material

Body, Carriage & Gate	300 Series ss
Bellows	AM-350 ss
Air Cylinder	Teflon® coated Aluminum
Bolts	300 Series ss, silver plated

Gaskets

Bonnet UHV / HV	OFE Copper / FKM / FPM fluoroelastomer elastomer
Gate	FKM / FPM fluoroelastomer or optional Kalrez® 4079
Piston	elastomer FKM / FPM fluoroelastomer elastomer

Electropneumatic Actuator

Air Pressure	70 to 100 psig
Air Control Valve	410 Series Humphrey solenoid valve
Solenoid Power	120VAC, 50/60Hz, 4W
Power Loss	Valve closes
Position Indicators	Mechanical, vernier adjustable, hinged-roller type micro switches suitable for 5A, 120/240VAC

Vacuum

Range	1x10 ⁻¹¹ Torr
Leak Test	2x10 ⁻¹⁰ cc/sec of He

Temperature Range Bakeability under vacuum in Open-Closed positions, with the following Bonnet-Gate seal combinations

Series	Open	Closed	Bonnet	Gate
UHV	200°C	150°C	Copper	FKM/FPM
UHV	250°C	200°C	Copper	Kalrez®
HV	150°C	150°C	FKM/FPM	FKM/FPM
			FKM/FPM	

Weight	See table
Dimensions	See table

Sealing

Valves will seal against 15 psi differential atmospheric pressure in either direction.

Orientation

Valves can be installed in either a vertical or horizontal orientation.

Leak Tightness

Each valve is tested using a helium mass spectrometer leak detector calibrated for a minimum sensitivity of 2x10⁻¹⁰ Std. Atm. cc/sec of He. Internal welds are inspected for pits, cracks, and other irregularities which may cause virtual leaks.

Maintenance

Carriage and gate mechanism may be removed through the bonnet flange for seal replacement, cleaning or retrofitting without removing the valve body from the system.

Manual Actuation

Actuators are constructed with non-rising Acme threads for smooth and quick operation. Visual open position indicators are standard on all manual valves.

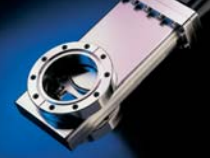

RECTANGULAR GATE VALVES

Specifications

Material

Body, Carriage & Gate	300 Series ss
Bellows	AM-350 ss
Air Cylinder	Teflon® coated Aluminum
Bolts	300 Series ss, silver plated

Gaskets

Bonnet	FKM / FPM fluoroelastomer elastomer
Gate	FKM / FPM fluoroelastomer elastomer
Piston	FKM / FPM fluoroelastomer elastomer

Electropneumatic Actuator

Air Pressure	70 to 100 psig
Air Control Valve	Herion, double impulse solenoid valve
Solenoid Power	24VDC
Power Loss	Valve remains in position during air or power failure
Position Indicators	Mechanical, vernier adjustable, hinged-roller type micro switches suitable for 5A, 120/240VAC

Vacuum

Range	1x10 ⁻⁸ Torr
Leak Test	2x10 ⁻¹⁰ cc/sec of He

Temperature Range

Bakeability under vacuum in Open-Closed positions, with the following Bonnet-Gate seal combination

Series	Open	Closed	Bonnet	Gate
HV	150°C	150°C	FKM/FPM	FKM/FPM

Weight

See table

Dimensions

See table

Sealing

Valves will seal against 15 psi differential atmospheric pressure in either direction.

Orientation

Valves can be installed in either a vertical or horizontal orientation.

Leak Tightness

Each valve is tested using a helium mass spectrometer leak detector calibrated for a minimum sensitivity of 2x10⁻¹⁰ Std. Atm. cc/sec of He. Internal welds are inspected for pits, cracks, and other irregularities which may cause virtual leaks.

Maintenance

Carriage and gate mechanism may be removed through the bonnet flange for seal replacement, cleaning or retrofitting without removing the valve body from the system.

Manual Actuation

Actuators are constructed with non-rising Acme threads for smooth and quick operation. Visual open position indicators are standard on all manual valves.

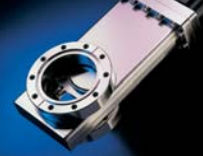

GV-625V

GV-625M-P

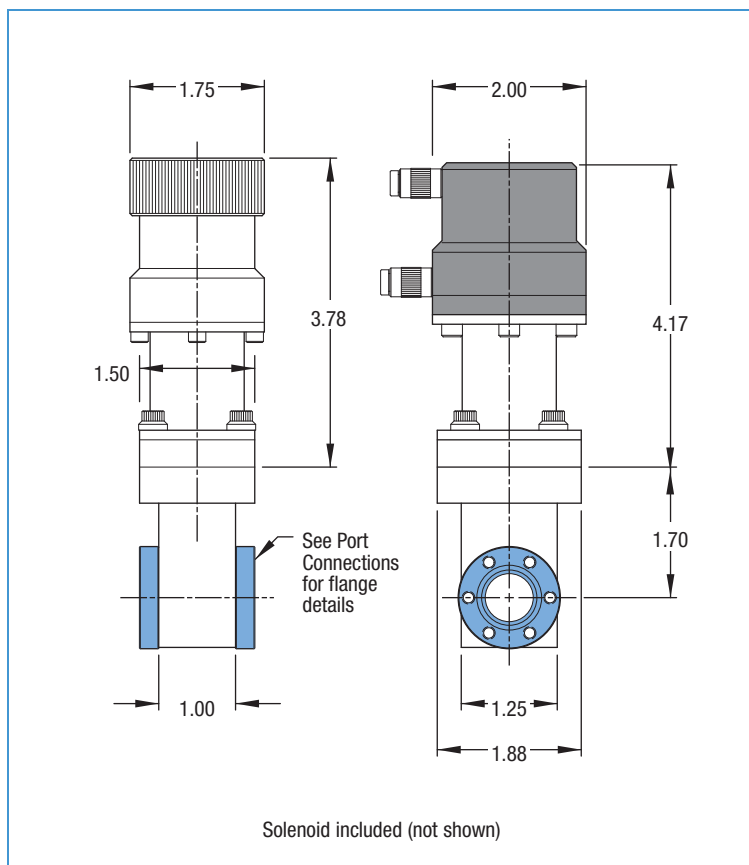

ULTRAHIGH VACUUM SERIES
250°C Metal Sealed Bonnets

HIGH VACUUM SERIES
150°C FKM / FPM fluoroelastomer
O-Ring Sealed Bonnets

Features

- FKM / FPM fluoroelastomer O-Ring Sealed Gates
- Stainless Steel Construction
- Manual or Electropneumatic Operation

PORT CONNECTIONS

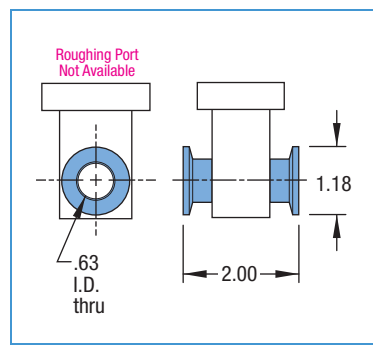
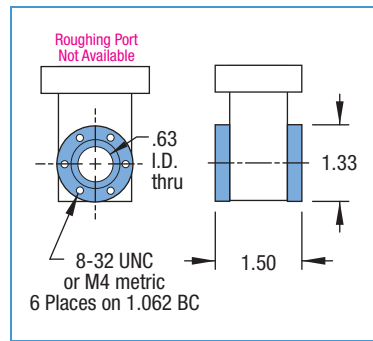

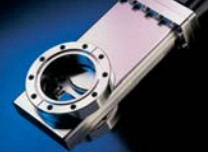

ULTRAHIGH VACUUM SERIES

METAL SEAL BONNET 250°C¹

ACTUATOR	PORT FLANGE	FLANGE THREAD	BONNET SEAL	WEIGHT POUNDS	REFERENCE	PART NUMBER
MANUAL	DEL-SEAL	UNC	METAL	2	GV-625M	302000
MANUAL	DEL-SEAL	METRIC	METAL	2	E-GV-625M	302011
PNEUMATIC	DEL-SEAL	UNC	METAL	2	GV-625M-P	303000
PNEUMATIC	DEL-SEAL	METRIC	METAL	2	E-GV-625M-P	303011

HIGH VACUUM SERIES

FKM / FPM SEAL BONNET 150°C¹

ACTUATOR	PORT FLANGE	FLANGE THREAD	BONNET SEAL	WEIGHT POUNDS	REFERENCE	PART NUMBER
MANUAL	DEL-SEAL	UNC	FKM/FPM	2	GV-625V	300000
MANUAL	DEL-SEAL	METRIC	FKM/FPM	2	E-GV-625V	300011
MANUAL	ISO	-	FKM/FPM	2	KGV-625V	306000
PNEUMATIC	DEL-SEAL	UNC	FKM/FPM	2	GV-625V-P	301000
PNEUMATIC	DEL-SEAL	METRIC	FKM/FPM	2	E-GV-625V-P	301011
PNEUMATIC	ISO	-	FKM/FPM	2	KGV-625V-P	307000

¹ See page 166 for detailed bakeout specification

VALVE OPTIONS



DESCRIPTION	OPTION NUMBER
24 VDC AIR CONTROL SOLENOID VALVE	-03
240 VAC AIR CONTROL SOLENOID VALVE	-09
KALREZ HIGH TEMP O-RING	-11

When ordering Gate Valve Options, please add the option number(s) to the end of the desired UHV or HV Series Gate Valve Part Number listed above. For example 303016-09
Detailed descriptions of each option begin on page 164.

ACCESSORIES

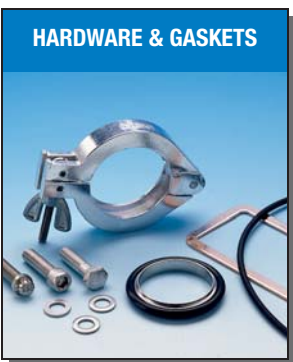

GASKET KIT	MATERIAL	QUANTITY PER PACK	REFERENCE	PART NUMBER
GATE & BONNET SEAL	FKM/FPM	1 ²	GVG-625	354000
GATE & BONNET SEAL	FKM/FPM & COPPER	1 ²	GVG-625M	355000

HARDWARE	THREAD LENGTH	FOR USE WITH	QUANTITY PER PACK	REFERENCE	PART NUMBER
SOCKET HEAD	8-32 x 1/2"	DEL-SEAL	25	BA-050-SP	190055
METRIC SOCKET HEAD	M4, 12mm LONG	DEL-SEAL	25	M4-12-SP	190167
CLAMP	-	ISO	1	K075-C	701000
CENTERING RING	-	ISO	1	K075-CR	710000

² Each gasket kit contains one Bonnet and one Gate seal

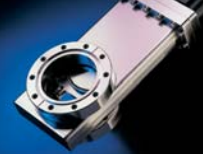

ULTRAHIGH VACUUM SERIES
250°C Metal Sealed Bonnets

HIGH VACUUM SERIES
150°C FKM / FPM fluoroelastomer
O-Ring Sealed Bonnets

Features

- FKM / FPM fluoroelastomer O-Ring Sealed Gates
- Stainless Steel Construction
- Manual or Electropneumatic Operation

PORT CONNECTIONS

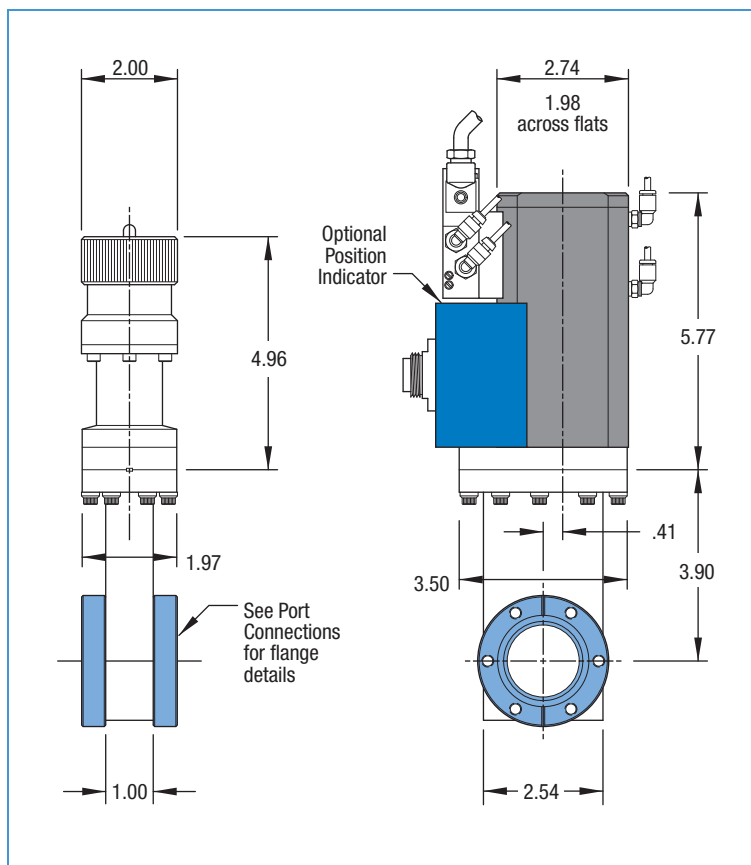
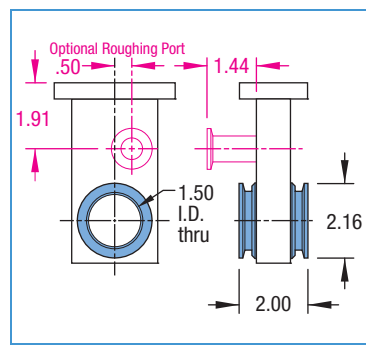
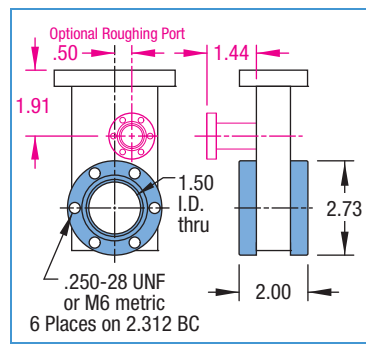

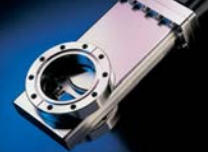

ULTRAHIGH VACUUM SERIES

METAL SEAL BONNET 250°C¹

ACTUATOR	PORT FLANGE	FLANGE THREAD	BONNET SEAL	WEIGHT POUNDS	REFERENCE	PART NUMBER
MANUAL	DEL-SEAL	UNF	METAL	6	GV-1500M	302001
MANUAL	DEL-SEAL	METRIC	METAL	6	E-GV-1500M	302012
PNEUMATIC	DEL-SEAL	UNF	METAL	6	GV-1500M-P	303001
PNEUMATIC	DEL-SEAL	METRIC	METAL	6	E-GV-1500M-P	303012

HIGH VACUUM SERIES

FKM / FPM SEAL BONNET 150°C¹

ACTUATOR	PORT FLANGE	FLANGE THREAD	BONNET SEAL	WEIGHT POUNDS	REFERENCE	PART NUMBER
MANUAL	DEL-SEAL	UNF	FKM/FPM	6	GV-1500V	300001
MANUAL	DEL-SEAL	METRIC	FKM/FPM	6	E-GV-1500V	300012
MANUAL	ISO	-	FKM/FPM	5	KGV-1500V	306001
PNEUMATIC	DEL-SEAL	UNF	FKM/FPM	6	GV-1500V-P	301001
PNEUMATIC	DEL-SEAL	METRIC	FKM/FPM	6	E-GV-1500V-P	301012
PNEUMATIC	ISO	-	FKM/FPM	5	KGV-1500V-P	307001

¹ See page 166 for detailed bakeout specification

VALVE OPTIONS



DESCRIPTION	OPTION NUMBER
MECHANICAL POSITION INDICATOR	-01
24 VDC AIR CONTROL SOLENOID VALVE	-03
240 VAC AIR CONTROL SOLENOID VALVE	-09
3/4" ROUGHING PORT	-04
KALREZ HIGH TEMP O-RING	-11

When ordering Gate Valve Options, please add the option number(s) to the end of the desired UHV or HV Series Gate Valve Part Number listed above. For example 303016-09
Detailed descriptions of each option begin on page 164.

ACCESSORIES

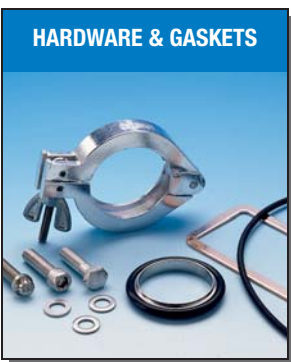

GASKET KIT	MATERIAL	QUANTITY PER PACK	REFERENCE	PART NUMBER
GATE & BONNET SEAL	FKM/FPM	1 ²	GVG-1500	354001
GATE & BONNET SEAL	FKM/FPM & COPPER	1 ²	GVG-1500M	355001

HARDWARE	THREAD LENGTH	FOR USE WITH	QUANTITY PER PACK	REFERENCE	PART NUMBER
12PT HEAD BOLT SET	.250-28 x 7/8"	DEL-SEAL	25	BA-085-12-SP	190057
METRIC HEX HEAD SET	M6, 20mm LONG	DEL-SEAL	25	M6-20-SP	190168
CLAMP	-	ISO	1	K150-C	701002
CENTERING RING	-	ISO	1	K150-CR	710002

² Each gasket kit contains one Bonnet and one Gate seal

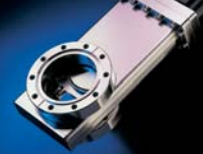

ULTRAHIGH VACUUM SERIES
250°C Metal Sealed Bonnets

HIGH VACUUM SERIES
150°C FKM / FPM fluoroelastomer
O-Ring Sealed Bonnets

Features

- FKM / FPM fluoroelastomer O-Ring Sealed Gates
- Stainless Steel Construction
- Manual or Electropneumatic Operation

PORT CONNECTIONS

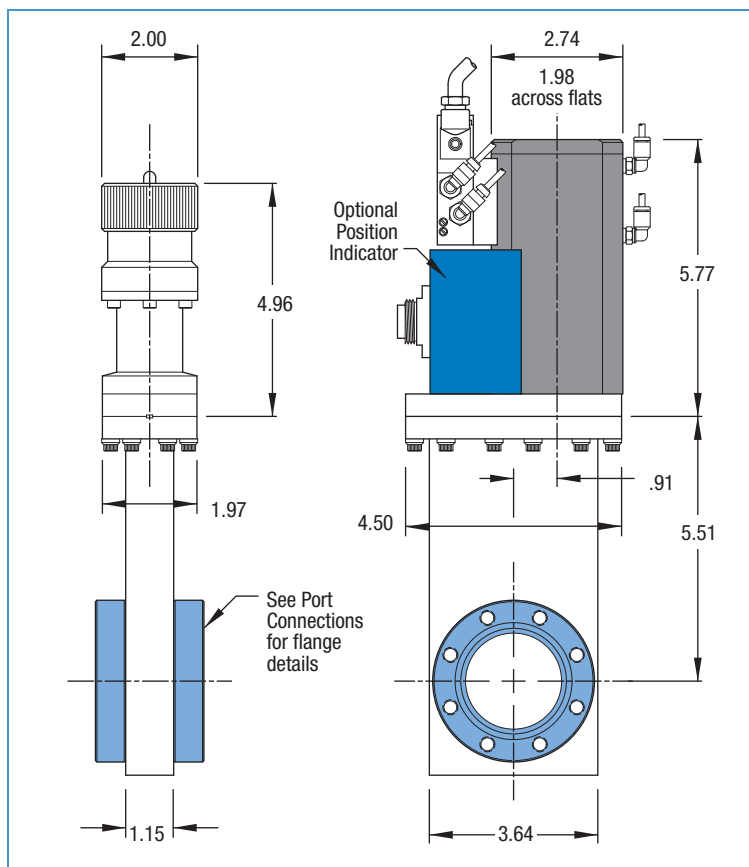
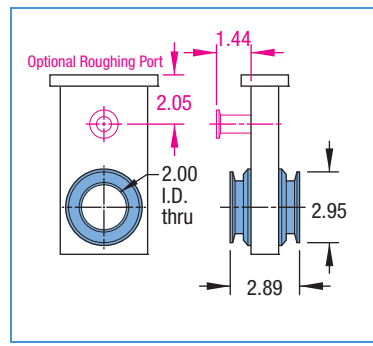
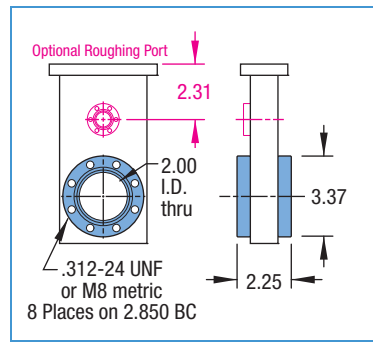



ULTRAHIGH VACUUM SERIES

METAL SEAL BONNET 250°C¹

ACTUATOR	PORT FLANGE	FLANGE THREAD	BONNET SEAL	WEIGHT POUNDS	REFERENCE	PART NUMBER
MANUAL	DEL-SEAL	UNF	METAL	11	GV-2000M	302010
MANUAL	DEL-SEAL	METRIC	METAL	11	E-GV-2000M	302013
PNEUMATIC	DEL-SEAL	UNF	METAL	11	GV-2000M-P	303010
PNEUMATIC	DEL-SEAL	METRIC	METAL	11	E-GV-2000M-P	303013

HIGH VACUUM SERIES

FKM / FPM SEAL BONNET 150°C¹

ACTUATOR	PORT FLANGE	FLANGE THREAD	BONNET SEAL	WEIGHT POUNDS	REFERENCE	PART NUMBER
MANUAL	DEL-SEAL	UNF	FKM/FPM	11	GV-2000V	300010
MANUAL	DEL-SEAL	METRIC	FKM/FPM	11	E-GV-2000V	300013
MANUAL	ISO	-	FKM/FPM	7	KGV-2000V	306002
PNEUMATIC	DEL-SEAL	UNF	FKM/FPM	11	GV-2000V-P	301010
PNEUMATIC	DEL-SEAL	METRIC	FKM/FPM	11	E-GV-2000V-P	301013
PNEUMATIC	ISO	-	FKM/FPM	7	KGV-2000V-P	307002

¹ See page 166 for detailed bakeout specification

VALVE OPTIONS



DESCRIPTION	OPTION NUMBER
MECHANICAL POSITION INDICATOR	-01
24 VDC AIR CONTROL SOLENOID VALVE	-03
240 VAC AIR CONTROL SOLENOID VALVE	-09
3/4" ROUGHING PORT	-04
KALREZ HIGH TEMP O-RING	-11

When ordering Gate Valve Options, please add the option number(s) to the end of the desired UHV or HV Series Gate Valve Part Number listed above. For example 303016-09
Detailed descriptions of each option begin on page 164.

ACCESSORIES

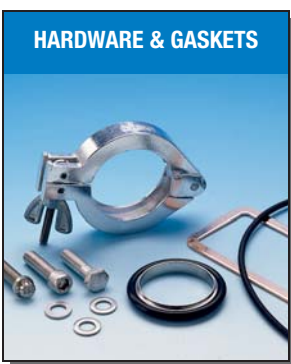

GASKET KIT	MATERIAL	QUANTITY PER PACK	REFERENCE	PART NUMBER
GATE & BONNET SEAL	FKM/FPM	1 ²	GVG-2000	354002
GATE & BONNET SEAL	FKM/FPM & COPPER	1 ²	GVG-2000M	355002

HARDWARE	THREAD LENGTH	USE WITH	QUANTITY PER PACK	REFERENCE	PART NUMBER
12PT HEAD BOLT SET	.312-24 x 1"	DEL-SEAL	25	BA-100-12-SP	190146
METRIC HEX HEAD SET	M8, 25mm LONG	DEL-SEAL	25	M8-25-SP	190169
CLAMP	-	ISO	1	K200-C	701003
CENTERING RING	-	ISO	1	K200-CR	710003

² Each gasket kit contains one Bonnet and one Gate seal

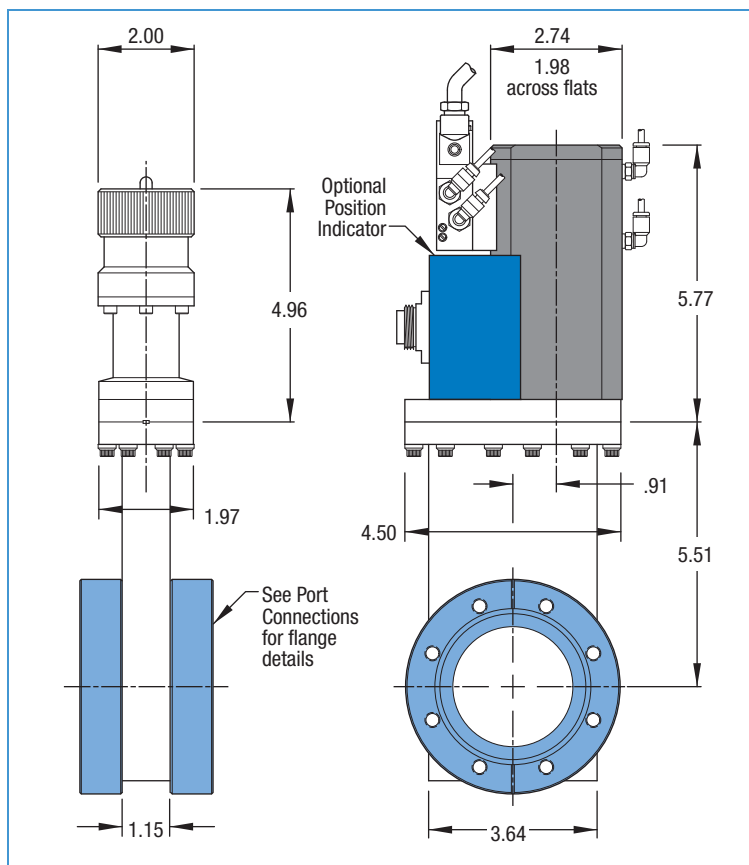
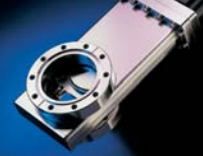

ULTRAHIGH VACUUM SERIES

250°C Metal Sealed Bonnets

HIGH VACUUM SERIES

150°C FKM / FPM fluoroelastomer O-Ring Sealed Bonnets

Features

- FKM / FPM fluoroelastomer O-Ring Sealed Gates
- Stainless Steel Construction
- Manual or Electropneumatic Operation

PORT CONNECTIONS

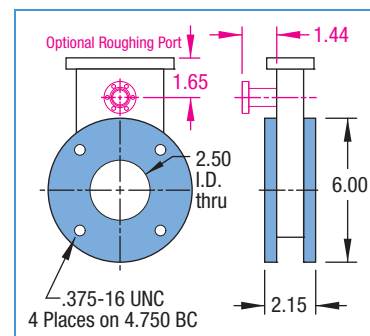
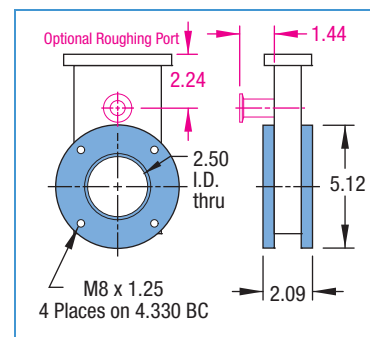
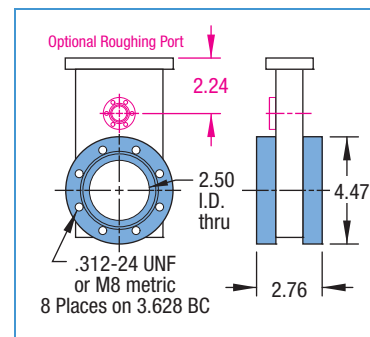

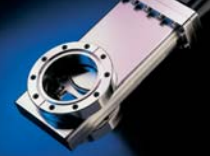

ULTRAHIGH VACUUM SERIES

METAL SEAL BONNET 250°C¹

ACTUATOR	PORT FLANGE	FLANGE THREAD	BONNET SEAL	WEIGHT POUNDS	REFERENCE	PART NUMBER
MANUAL	DEL-SEAL	UNF	METAL	11	GV-2500M	302002
MANUAL	DEL-SEAL	METRIC	METAL	11	E-GV-2500M	302014
PNEUMATIC	DEL-SEAL	UNF	METAL	11	GV-2500M-P	303002
PNEUMATIC	DEL-SEAL	METRIC	METAL	11	E-GV-2500M-P	303014

HIGH VACUUM SERIES

FKM / FPM SEAL BONNET 150°C¹

ACTUATOR	PORT FLANGE	FLANGE THREAD	BONNET SEAL	WEIGHT POUNDS	REFERENCE	PART NUMBER
MANUAL	DEL-SEAL	UNF	FKM/FPM	11	GV-2500V	300002
MANUAL	DEL-SEAL	METRIC	FKM/FPM	11	E-GV-2500V	300014
MANUAL	ISO	METRIC	FKM/FPM	10	LGV-2500V	306003
MANUAL	ASA	UNC	FKM/FPM	11	GV-2500V-ASA	304000
PNEUMATIC	DEL-SEAL	UNF	FKM/FPM	11	GV-2500V-P	301002
PNEUMATIC	DEL-SEAL	METRIC	FKM/FPM	11	E-GV-2500V-P	301014
PNEUMATIC	ISO	METRIC	FKM/FPM	10	LGV-2500V-P	307003
PNEUMATIC	ASA	UNC	FKM/FPM	11	GV-2500V-ASA-P	305000

¹ See page 166 for detailed bakeout specification

VALVE OPTIONS



DESCRIPTION	OPTION NUMBER
MECHANICAL POSITION INDICATOR	-01
24 VDC AIR CONTROL SOLENOID VALVE	-03
240 VAC AIR CONTROL SOLENOID VALVE	-09
3/4" ROUGHING PORT	-04
KALREZ HIGH TEMP O-RING	-11

When ordering Gate Valve Options, please add the option number(s) to the end of the desired UHV or HV Series Gate Valve Part Number listed above. For example 303016-09
Detailed descriptions of each option begin on page 164.

ACCESSORIES

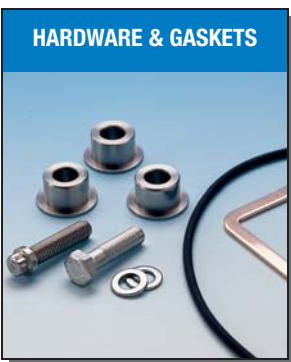

GASKET KIT	MATERIAL	QUANTITY PER PACK	REFERENCE	PART NUMBER
GATE & BONNET SEAL	FKM/FPM	1 ²	GVG-2500	354002
GATE & BONNET SEAL	FKM/FPM & COPPER	1 ²	GVG-2500M	355002

HARDWARE	THREAD LENGTH	FOR USE WITH	QUANTITY PER PACK	REFERENCE	PART NUMBER
12PT HEAD BOLT SET	.312-24 x 1-1/4"	DEL-SEAL	25	BA-125-12-SP	190058
METRIC HEX HEAD SET	M8, 35mm LONG	DEL-SEAL	25	M8-35-SP	190170
METRIC HEX HEAD SET	M8, 25mm LONG	ISO	25	M8-25-SP	190169
HEX HEAD SET ³	.375-16 x 1"	ASA	8	GVBA-250-SP	190175
BOLT HOLE BUSHING	3/4" TO 3/8" REDUCER	ASA	8	GVBHB	190110

² Each gasket kit contains one Bonnet and one Gate seal

³ Includes bolt hole bushings

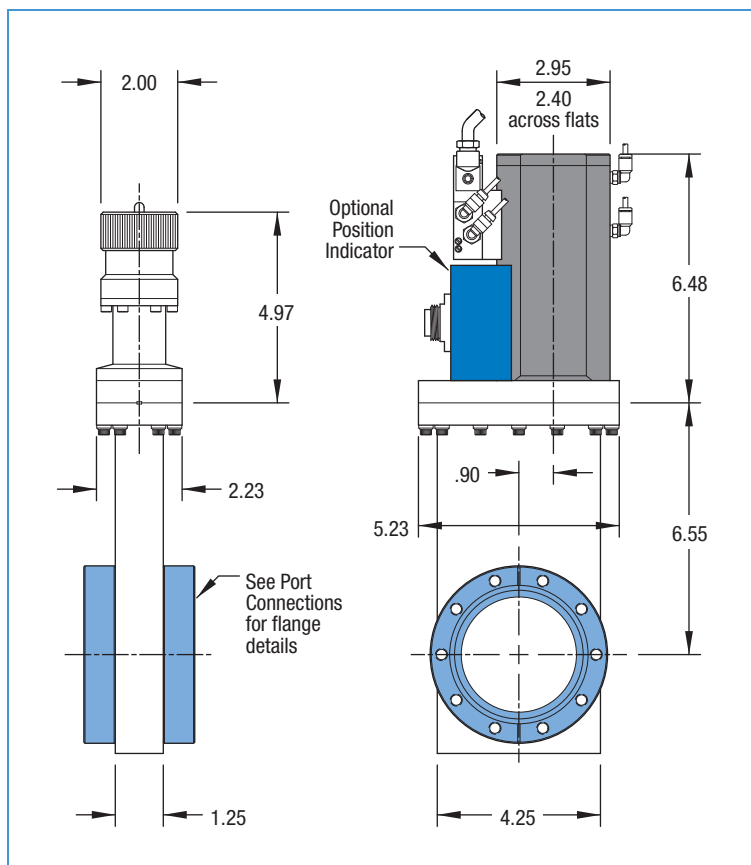
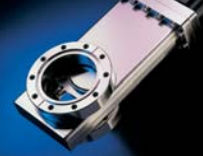

ULTRAHIGH VACUUM SERIES

250°C Metal Sealed Bonnets

HIGH VACUUM SERIES

150°C FKM / FPM fluoroelastomer O-Ring Sealed Bonnets

Features

- FKM / FPM fluoroelastomer O-Ring Sealed Gates
- Stainless Steel Construction
- Manual or Electropneumatic Operation

PORT CONNECTIONS

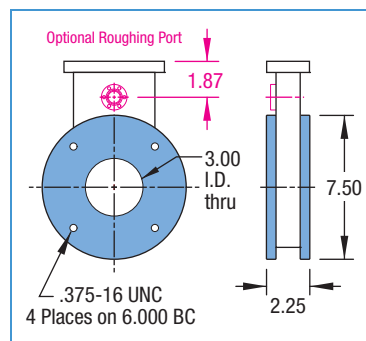
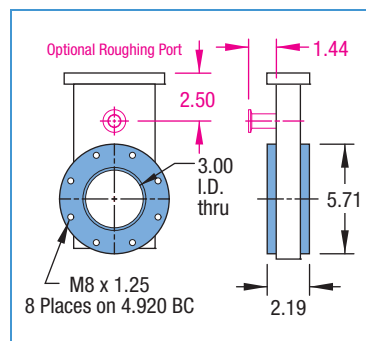
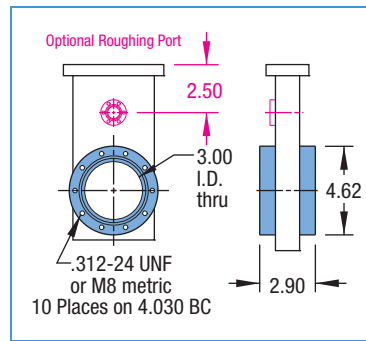

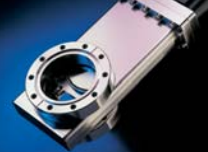

ULTRAHIGH VACUUM SERIES

METAL SEAL BONNET 250°C¹

ACTUATOR	PORT FLANGE	FLANGE THREAD	BONNET SEAL	WEIGHT POUNDS	REFERENCE	PART NUMBER
MANUAL	DEL-SEAL	UNF	METAL	22	GV-3000M	302003
MANUAL	DEL-SEAL	METRIC	METAL	22	E-GV-3000M	302015
PNEUMATIC	DEL-SEAL	UNF	METAL	22	GV-3000M-P	303003
PNEUMATIC	DEL-SEAL	METRIC	METAL	22	E-GV-3000M-P	303015

HIGH VACUUM SERIES

FKM / FPM SEAL BONNET 150°C¹

ACTUATOR	PORT FLANGE	FLANGE THREAD	BONNET SEAL	WEIGHT POUNDS	REFERENCE	PART NUMBER
MANUAL	DEL-SEAL	UNF	FKM/FPM	22	GV-3000V	300003
MANUAL	DEL-SEAL	METRIC	FKM/FPM	22	E-GV-3000V	300015
MANUAL	ISO	METRIC	FKM/FPM	20	LGV-3000V	306004
MANUAL	ASA	UNC	FKM/FPM	22	GV-3000V-ASA	304001
PNEUMATIC	DEL-SEAL	UNF	FKM/FPM	22	GV-3000V-P	301003
PNEUMATIC	DEL-SEAL	METRIC	FKM/FPM	22	E-GV-3000V-P	301015
PNEUMATIC	ISO	METRIC	FKM/FPM	20	LGV-3000V-P	307004
PNEUMATIC	ASA	UNC	FKM/FPM	22	GV-3000V-ASA-P	305001

¹ See page 166 for detailed bakeout specification

VALVE OPTIONS



DESCRIPTION	OPTION NUMBER
MECHANICAL POSITION INDICATOR	-01
24 VDC AIR CONTROL SOLENOID VALVE	-03
240 VAC AIR CONTROL SOLENOID VALVE	-09
3/4" ROUGHING PORT	-04
KALREZ HIGH TEMP O-RING	-11

When ordering Gate Valve Options, please add the option number(s) to the end of the desired UHV or HV Series Gate Valve Part Number listed above. For example 303016-09
Detailed descriptions of each option begin on page 164.

ACCESSORIES

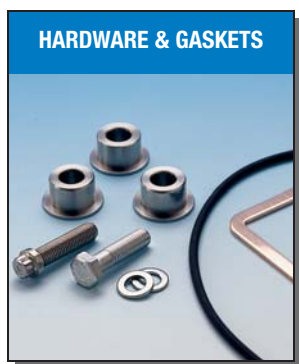

GASKET KIT	MATERIAL	QUANTITY PER PACK	REFERENCE	PART NUMBER
GATE & BONNET SEAL	FKM/FPM	1 ²	GVG-3000	354003
GATE & BONNET SEAL	FKM/FPM & COPPER	1 ²	GVG-3000M	355003

HARDWARE	THREAD LENGTH	FOR USE WITH	QUANTITY PER PACK	REFERENCE	PART NUMBER
12PT HEAD BOLT SET	.312-24 x 1-1/4"	DEL-SEAL	25	BA-125-12-SP	190058
METRIC HEX HEAD SET	M8, 35mm LONG	DEL-SEAL	25	M8-35-SP	190170
METRIC HEX HEAD SET	M8, 25mm LONG	ISO	25	M8-25-SP	190169
HEX HEAD SET ³	.375-16 x 1"	ASA	8	GVBA-300-SP	190175
BOLT HOLE BUSHING	3/4" TO 3/8" REDUCER	ASA	8	GVBHB	190110

² Each gasket kit contains one Bonnet and one Gate seal

³ Includes bolt hole bushings

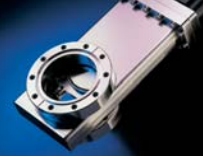

ULTRAHIGH VACUUM SERIES
250°C Metal Sealed Bonnets

HIGH VACUUM SERIES
150°C FKM / FPM fluoroelastomer
O-Ring Sealed Bonnets

Features

- FKM / FPM fluoroelastomer O-Ring Sealed Gates
- Stainless Steel Construction
- Manual or Electropneumatic Operation

PORT CONNECTIONS

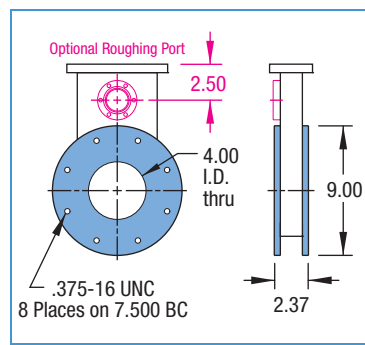
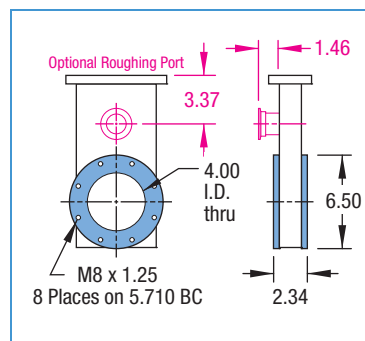
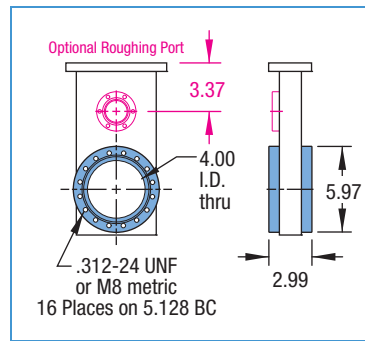
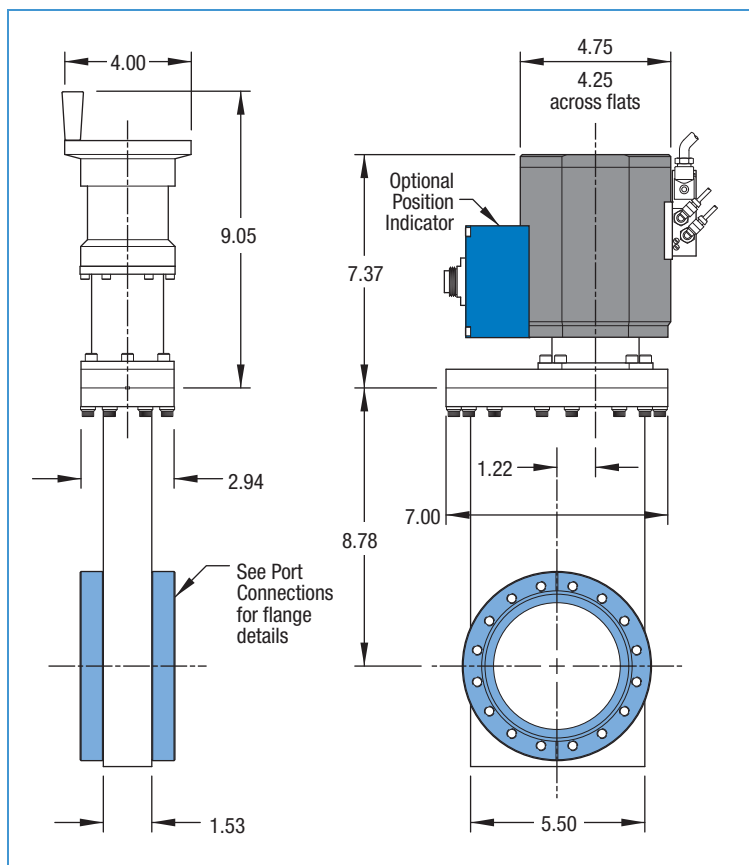

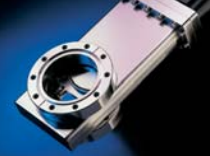

ULTRAHIGH VACUUM SERIES

METAL SEAL BONNET 250°C¹

ACTUATOR	PORT FLANGE	FLANGE THREAD	BONNET SEAL	WEIGHT POUNDS	REFERENCE	PART NUMBER
MANUAL	DEL-SEAL	UNF	METAL	25	GV-4000M	302004
MANUAL	DEL-SEAL	METRIC	METAL	25	E-GV-4000M	302016
PNEUMATIC	DEL-SEAL	UNF	METAL	25	GV-4000M-P	303004
PNEUMATIC	DEL-SEAL	METRIC	METAL	25	E-GV-4000M-P	303016

HIGH VACUUM SERIES

FKM / FPM SEAL BONNET 150°C¹

ACTUATOR	PORT FLANGE	FLANGE THREAD	BONNET SEAL	WEIGHT POUNDS	REFERENCE	PART NUMBER
MANUAL	DEL-SEAL	UNF	FKM/FPM	25	GV-4000V	300004
MANUAL	DEL-SEAL	METRIC	FKM/FPM	25	E-GV-4000V	300016
MANUAL	ISO	METRIC	FKM/FPM	25	LGV-4000V	306005
MANUAL	ASA	UNC	FKM/FPM	25	GV-4000V-ASA	304002
PNEUMATIC	DEL-SEAL	UNF	FKM/FPM	25	GV-4000V-P	301004
PNEUMATIC	DEL-SEAL	METRIC	FKM/FPM	25	E-GV-4000V-P	301016
PNEUMATIC	ISO	METRIC	FKM/FPM	25	LGV-4000V-P	307005
PNEUMATIC	ASA	UNC	FKM/FPM	25	GV-4000V-ASA-P	305002

¹ See page 166 for detailed bakeout specification

VALVE OPTIONS



DESCRIPTION	OPTION NUMBER
MECHANICAL POSITION INDICATOR	-01
24 VDC AIR CONTROL SOLENOID VALVE	-03
240 VAC AIR CONTROL SOLENOID VALVE	-09
1-1/2" ROUGHING PORT	-05
KALREZ HIGH TEMP O-RING	-11

When ordering Gate Valve Options, please add the option number(s) to the end of the desired UHV or HV Series Gate Valve Part Number listed above. For example 303016-09
Detailed descriptions of each option begin on page 164.

ACCESSORIES

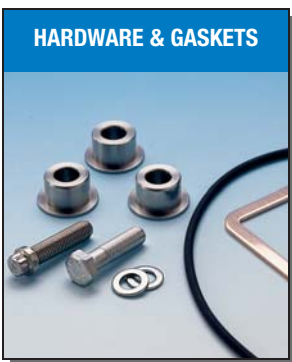

GASKET KIT		MATERIAL	QUANTITY PER PACK	REFERENCE	PART NUMBER
GATE & BONNET SEAL		FKM/FPM	1 ²	GVG-4000	354004
GATE & BONNET SEAL		FKM/FPM & COPPER	1 ²	GVG-4000M	355004

HARDWARE	THREAD LENGTH	FOR USE WITH	QUANTITY PER PACK	REFERENCE	PART NUMBER
12PT HEAD BOLT SET	.312-24 x 1-1/4"	DEL-SEAL	25	BA-125-12-SP	190058
METRIC HEX HEAD SET	M8, 35mm LONG	DEL-SEAL	25	M8-35-SP	190170
METRIC HEX HEAD SET	M8, 25mm LONG	ISO	25	M8-25-SP	190169
HEX HEAD SET ³	.375-16 x 1"	ASA	16	GVBA-400-SP	190176
BOLT HOLE BUSHING	3/4" TO 3/8" REDUCER	ASA	8	GVBHB	190110

² Each gasket kit contains one Bonnet and one Gate seal

³ Includes bolt hole bushings

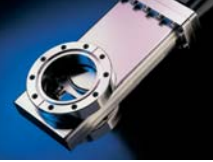

ULTRAHIGH VACUUM SERIES
250°C Metal Sealed Bonnets

HIGH VACUUM SERIES
150°C FKM / FPM fluoroelastomer
O-Ring Sealed Bonnets

Features

- FKM / FPM fluoroelastomer O-Ring Sealed Gates
- Stainless Steel Construction
- Manual or Electropneumatic Operation

PORT CONNECTIONS

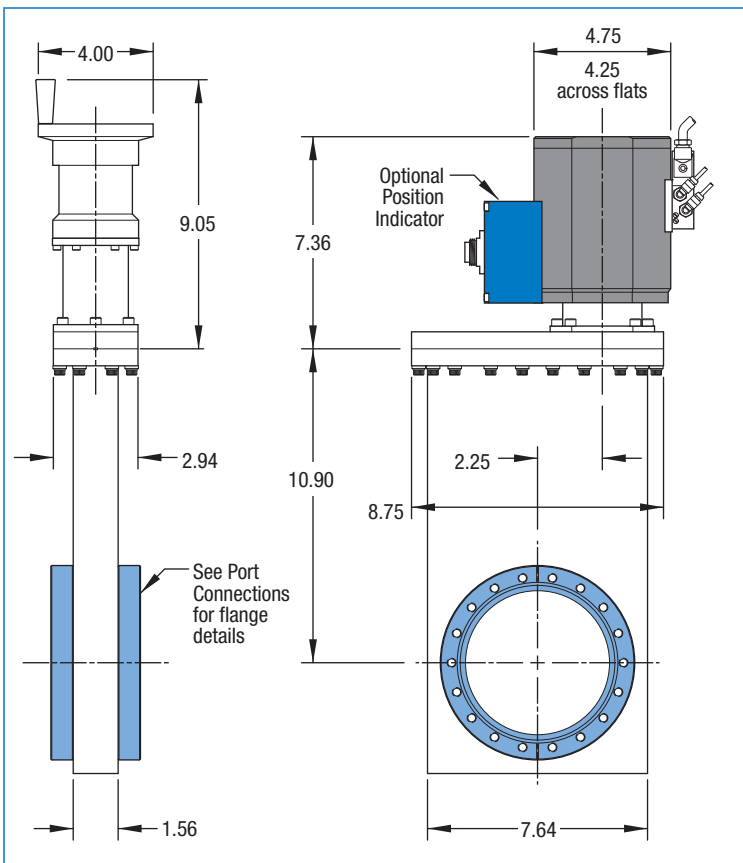
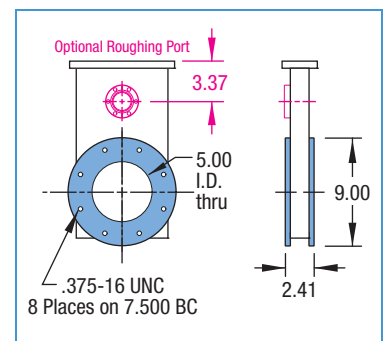
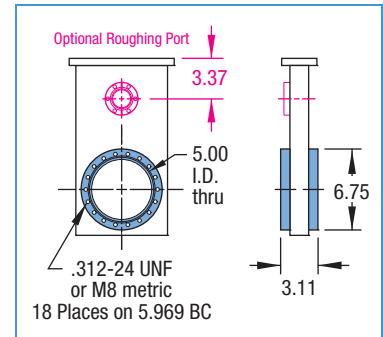

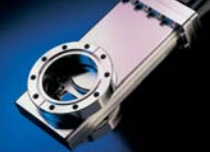

ULTRAHIGH VACUUM SERIES

METAL SEAL BONNET 250°C¹

ACTUATOR	PORT FLANGE	FLANGE THREAD	BONNET SEAL	WEIGHT POUNDS	REFERENCE	PART NUMBER
MANUAL	DEL-SEAL	UNF	METAL	35	GV-5000M	302005
MANUAL	DEL-SEAL	METRIC	METAL	35	E-GV-5000M	302017
PNEUMATIC	DEL-SEAL	UNF	METAL	36	GV-5000M-P	303005
PNEUMATIC	DEL-SEAL	METRIC	METAL	35	E-GV-5000M-P	303017

HIGH VACUUM SERIES

FKM / FPM SEAL BONNET 150°C¹

ACTUATOR	PORT FLANGE	FLANGE THREAD	BONNET SEAL	WEIGHT POUNDS	REFERENCE	PART NUMBER
MANUAL	DEL-SEAL	UNF	FKM/FPM	35	GV-5000V	300005
MANUAL	DEL-SEAL	METRIC	FKM/FPM	35	E-GV-5000V	300017
MANUAL	ASA	UNC	FKM/FPM	35	GV-5000V-ASA	304003
PNEUMATIC	DEL-SEAL	UNF	FKM/FPM	35	GV-5000V-P	301005
PNEUMATIC	DEL-SEAL	METRIC	FKM/FPM	35	E-GV-5000V-P	301017
PNEUMATIC	ASA	UNC	FKM/FPM	35	GV-5000V-ASA-P	305003

¹ See page 166 for detailed bakeout specification

VALVE OPTIONS



DESCRIPTION	OPTION NUMBER
MECHANICAL POSITION INDICATOR	-01
24 VDC AIR CONTROL SOLENOID VALVE	-03
240 VAC AIR CONTROL SOLENOID VALVE	-09
1-1/2" ROUGHING PORT	-05
KALREZ HIGH TEMP O-RING	-11

When ordering Gate Valve Options, please add the option number(s) to the end of the desired UHV or HV Series Gate Valve Part Number listed above. For example 303016-09
Detailed descriptions of each option begin on page 164.

ACCESSORIES

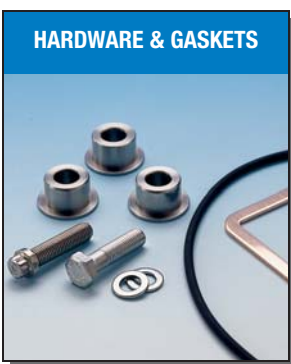

GASKET KIT	MATERIAL	QUANTITY PER PACK	REFERENCE	PART NUMBER
GATE & BONNET SEAL	FKM/FPM	1 ²	GVG-5000	354006
GATE & BONNET SEAL	FKM/FPM & COPPER	1 ²	GVG-5000M	355006

HARDWARE	THREAD LENGTH	FOR USE WITH	QUANTITY PER PACK	REFERENCE	PART NUMBER
12PT HEAD BOLT SET	.312-24 x 1-1/4"	DEL-SEAL	25	BA-125-12-SP	190058
METRIC HEX HEAD SET	M8, 35mm LONG	DEL-SEAL	25	M8-35-SP	190170
HEX HEAD SET ³	.375-16 x 1"	ASA	16	GVBA-500-SP	190176
BOLT HOLE BUSHING	3/4" TO 3/8" REDUCER	ASA	8	GVBHB	190110

² Each gasket kit contains one Bonnet and one Gate seal

³ Includes bolt hole bushings

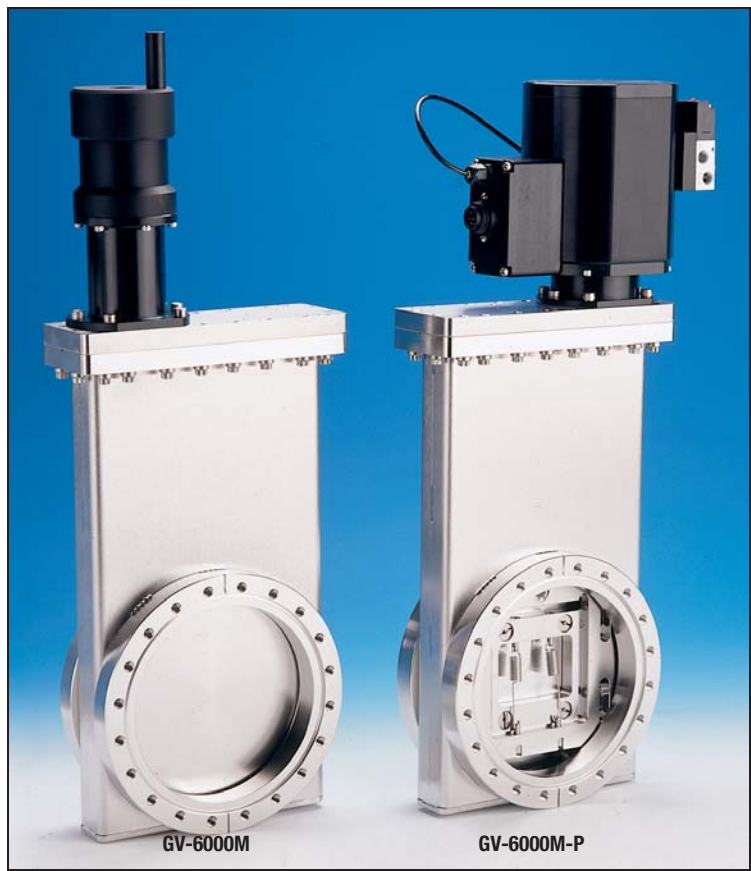
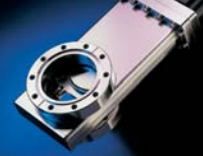

ULTRAHIGH VACUUM SERIES
250°C Metal Sealed Bonnets

HIGH VACUUM SERIES
150°C FKM / FPM fluoroelastomer
O-Ring Sealed Bonnets

Features

- FKM / FPM fluoroelastomer O-Ring Sealed Gates
- Stainless Steel Construction
- Manual or Electropneumatic Operation

PORT CONNECTIONS

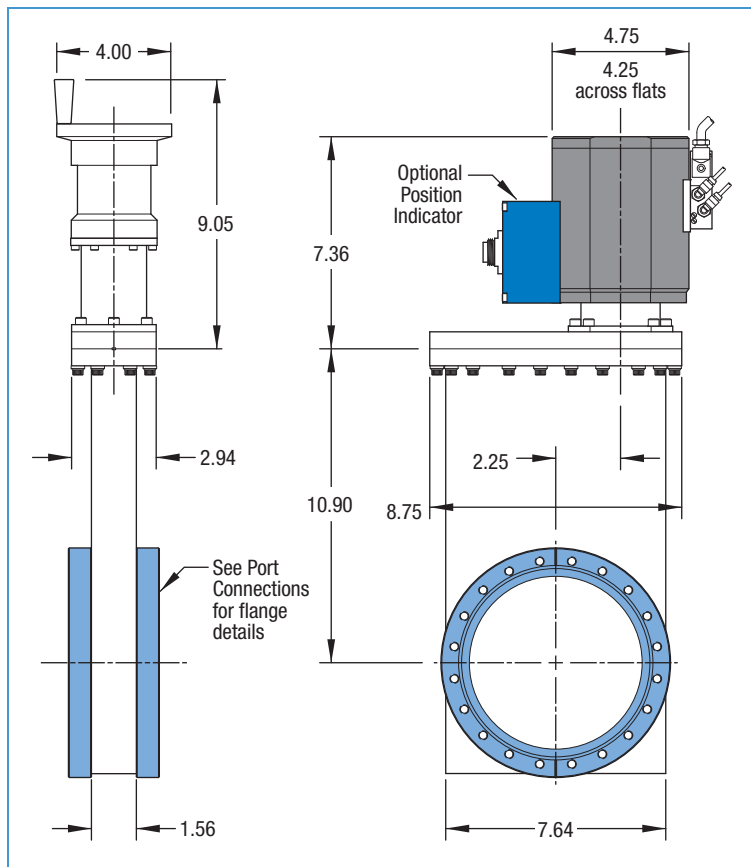
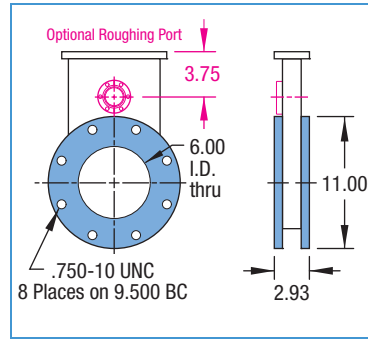
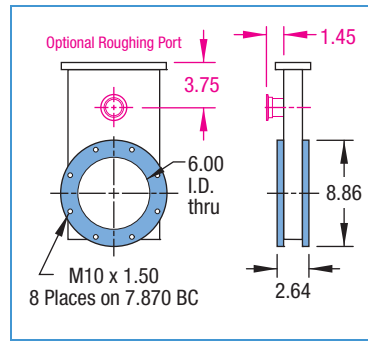
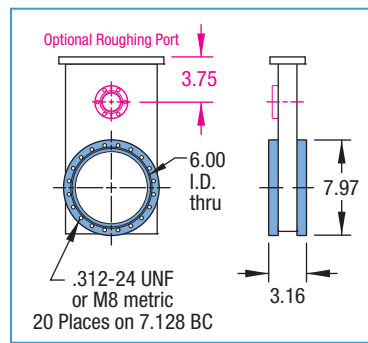



ULTRAHIGH VACUUM SERIES

METAL SEAL BONNET 250°C¹

ACTUATOR	PORT FLANGE	FLANGE THREAD	BONNET SEAL	WEIGHT POUNDS	REFERENCE	PART NUMBER
MANUAL	DEL-SEAL	UNF	METAL	37	GV-6000M	302006
MANUAL	DEL-SEAL	METRIC	METAL	37	E-GV-6000M	302018
PNEUMATIC	DEL-SEAL	UNF	METAL	37	GV-6000M-P	303006
PNEUMATIC	DEL-SEAL	METRIC	METAL	37	E-GV-6000M-P	303018

HIGH VACUUM SERIES

FKM / FPM SEAL BONNET 150°C¹

ACTUATOR	PORT FLANGE	FLANGE THREAD	BONNET SEAL	WEIGHT POUNDS	REFERENCE	PART NUMBER
MANUAL	DEL-SEAL	UNF	FKM/FPM	37	GV-6000V	300006
MANUAL	DEL-SEAL	METRIC	FKM/FPM	37	E-GV-6000V	300018
MANUAL	ISO	METRIC	FKM/FPM	35	LGV-6000V	306006
MANUAL	ASA	UNC	FKM/FPM	37	GV-6000V-ASA	304004
PNEUMATIC	DEL-SEAL	UNF	FKM/FPM	37	GV-6000V-P	301006
PNEUMATIC	DEL-SEAL	METRIC	FKM/FPM	37	E-GV-6000V-P	301018
PNEUMATIC	ISO	METRIC	FKM/FPM	35	LGV-6000V-P	307006
PNEUMATIC	ASA	UNC	FKM/FPM	37	GV-6000V-ASA-P	305004

¹ See page 166 for detailed bakeout specification

VALVE OPTIONS



DESCRIPTION	OPTION NUMBER
MECHANICAL POSITION INDICATOR	-01
24 VDC AIR CONTROL SOLENOID VALVE	-03
240 VAC AIR CONTROL SOLENOID VALVE	-09
1-1/2" ROUGHING PORT	-05
KALREZ HIGH TEMP O-RING	-11

When ordering Gate Valve Options, please add the option number(s) to the end of the desired UHV or HV Series Gate Valve Part Number listed above. For example 303016-09
Detailed descriptions of each option begin on page 164.

ACCESSORIES

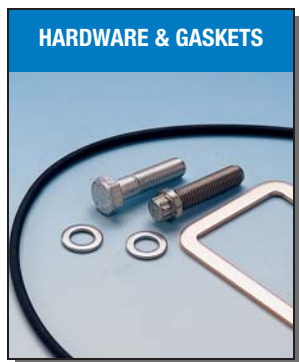

GASKET KIT	MATERIAL	QUANTITY PER PACK	REFERENCE	PART NUMBER
GATE & BONNET SEAL	FKM/FPM	1 ²	GVG-6000	354006
GATE & BONNET SEAL	FKM/FPM & COPPER	1 ²	GVG-6000M	355006

HARDWARE	THREAD LENGTH	FOR USE WITH	QUANTITY PER PACK	REFERENCE	PART NUMBER
12PT HEAD BOLT SET	.312-24 x 1-3/4"	DEL-SEAL	25	BA-600-12-SP	190059
METRIC HEX HEAD SET	M8, 40mm LONG	DEL-SEAL	25	M8-40-SP	190171
METRIC HEX HEAD SET	M10, 30mm LONG	ISO	25	M10-30-SP	190172
HEX HEAD SET	.750-10 x 1-1/2"	ASA	16	GVBA-600-SP	190177

² Each gasket kit contains one Bonnet and one Gate seal

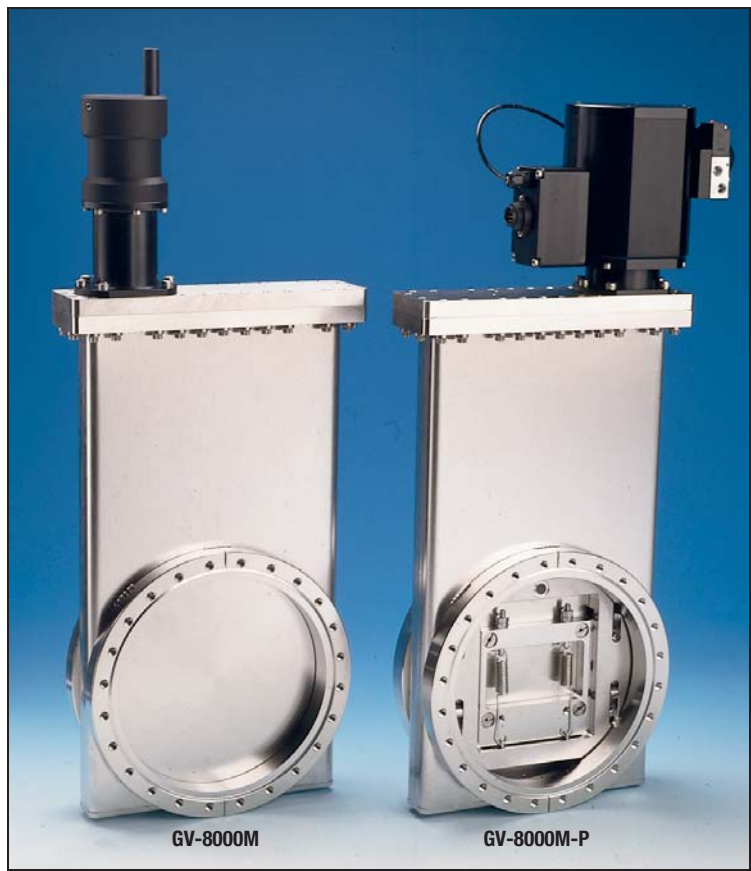
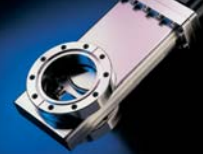

GV-8000M

GV-8000M-P

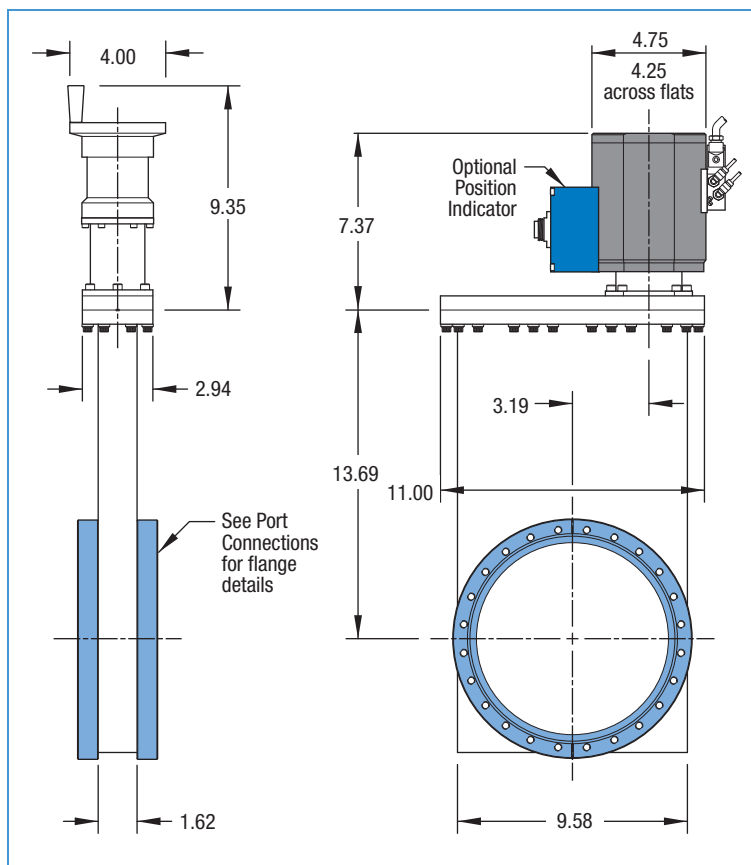

ULTRAHIGH VACUUM SERIES

250°C Metal Sealed Bonnets

HIGH VACUUM SERIES

150°C FKM / FPM fluoroelastomer O-Ring Sealed Bonnets

Features

- FKM / FPM fluoroelastomer O-Ring Sealed Gates
- Stainless Steel Construction
- Manual or Electropneumatic Operation

PORT CONNECTIONS

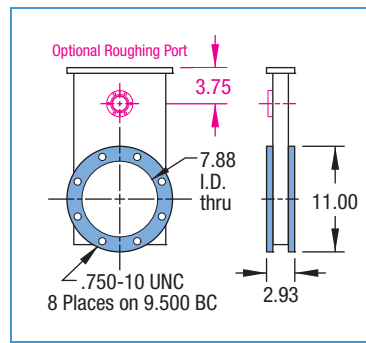
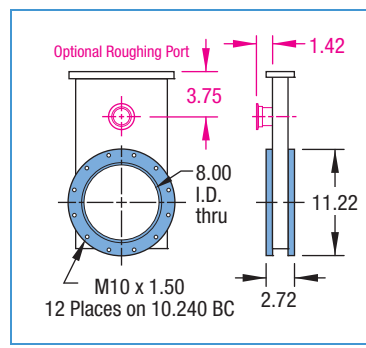
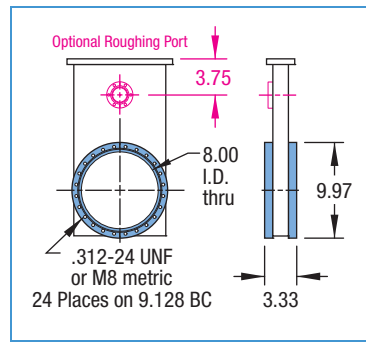

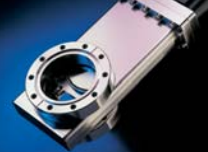

ULTRAHIGH VACUUM SERIES

METAL SEAL BONNET 250°C¹

ACTUATOR	PORT FLANGE	FLANGE THREAD	BONNET SEAL	WEIGHT POUNDS	REFERENCE	PART NUMBER
MANUAL	DEL-SEAL	UNF	METAL	55	GV-8000M	302007
MANUAL	DEL-SEAL	METRIC	METAL	55	E-GV-8000M	302019
PNEUMATIC	DEL-SEAL	UNF	METAL	55	GV-8000M-P	303007
PNEUMATIC	DEL-SEAL	METRIC	METAL	55	E-GV-8000M-P	303019

HIGH VACUUM SERIES

FKM / FPM SEAL BONNET 150°C¹

ACTUATOR	PORT FLANGE	FLANGE THREAD	BONNET SEAL	WEIGHT POUNDS	REFERENCE	PART NUMBER
MANUAL	DEL-SEAL	UNF	FKM/FPM	55	GV-8000V	300007
MANUAL	DEL-SEAL	METRIC	FKM/FPM	55	E-GV-8000V	300019
MANUAL	ISO	METRIC	FKM/FPM	50	LGV-8000V	306007
MANUAL	ASA	UNC	FKM/FPM	55	GV-8000V-ASA	304005
PNEUMATIC	DEL-SEAL	UNF	FKM/FPM	55	GV-8000V-P	301007
PNEUMATIC	DEL-SEAL	METRIC	FKM/FPM	55	E-GV-8000V-P	301019
PNEUMATIC	ISO	METRIC	FKM/FPM	50	LGV-8000V-P	307007
PNEUMATIC	ASA	UNC	FKM/FPM	55	GV-8000V-ASA-P	305005

¹ See page 166 for detailed bakeout specification

VALVE OPTIONS



DESCRIPTION	OPTION NUMBER
MECHANICAL POSITION INDICATOR	-01
24 VDC AIR CONTROL SOLENOID VALVE	-03
240 VAC AIR CONTROL SOLENOID VALVE	-09
1-1/2" ROUGHING PORT	-05
KALREZ HIGH TEMP O-RING	-11

When ordering Gate Valve Options, please add the option number(s) to the end of the desired UHV or HV Series Gate Valve Part Number listed above. For example 303016-09
Detailed descriptions of each option begin on page 164.

ACCESSORIES

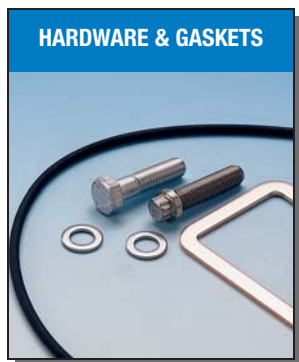

GASKET KIT	MATERIAL	QUANTITY PER PACK	REFERENCE	PART NUMBER
GATE & BONNET SEAL	FKM/FPM	1 ²	GVG-8000	354007
GATE & BONNET SEAL	FKM/FPM & COPPER	1 ²	GVG-8000M	355007

HARDWARE	THREAD LENGTH	FOR USE WITH	QUANTITY PER PACK	REFERENCE	PART NUMBER
12PT HEAD BOLT SET	.312-24 X 1-3/4"	DEL-SEAL	25	BA-600-12-SP	190059
METRIC HEX HEAD SET	M8, 40mm LONG	DEL-SEAL	25	M8-40-SP	190171
METRIC HEX HEAD SET	M10, 30mm LONG	ISO	25	M10-30-SP	190172
HEX HEAD SET	.750-10 X 1-1/2"	ASA	16	GVBA-800-SP	190177

² Each gasket kit contains one Bonnet and one Gate seal

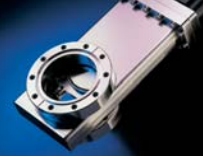

GV-10000M

GV-10000M-P

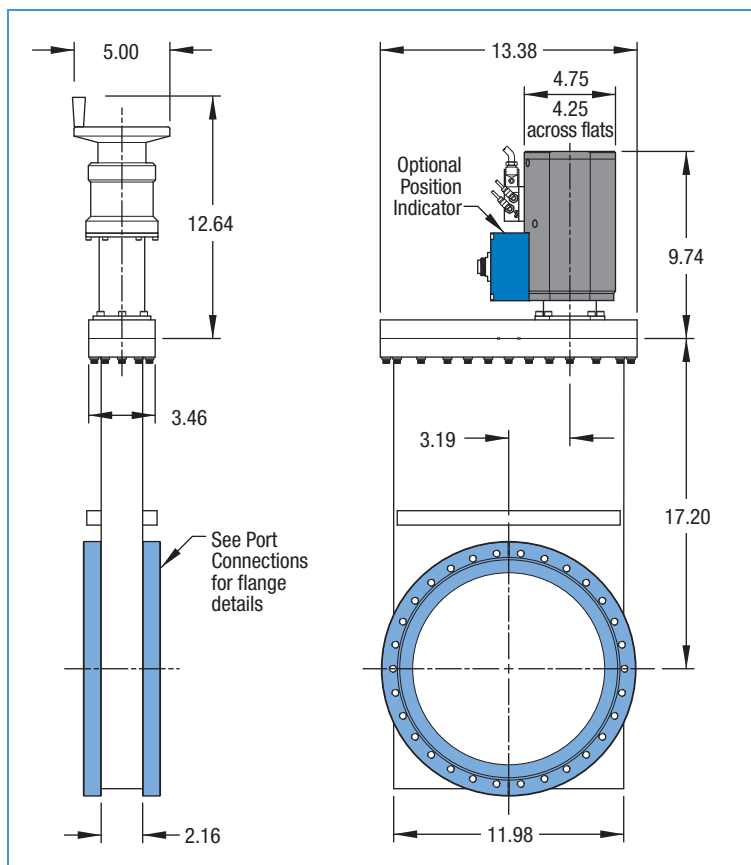

ULTRAHIGH VACUUM SERIES

250°C Metal Sealed Bonnets

HIGH VACUUM SERIES

150°C FKM / FPM fluoroelastomer O-Ring Sealed Bonnets

Features

- FKM / FPM fluoroelastomer O-Ring Sealed Gates
- Stainless Steel Construction
- Manual or Electropneumatic Operation

PORT CONNECTIONS

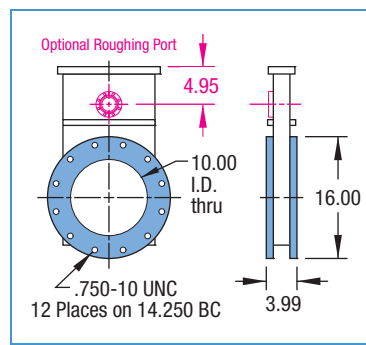
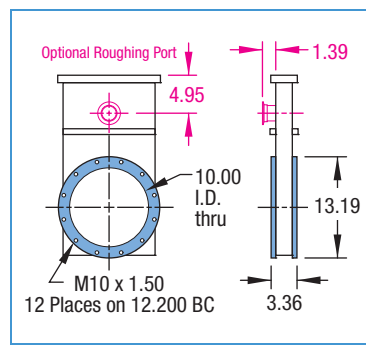
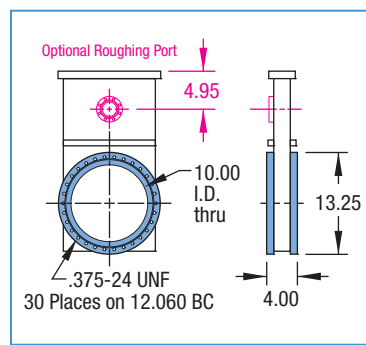



ULTRAHIGH VACUUM SERIES

METAL SEAL BONNET 250°C¹

ACTUATOR	PORT FLANGE	FLANGE THREAD	BONNET SEAL	WEIGHT POUNDS	REFERENCE	PART NUMBER
MANUAL	DEL-SEAL	UNF	METAL	110	GV-10000M	302008
PNEUMATIC	DEL-SEAL	UNF	METAL	110	GV-10000M-P	303008

HIGH VACUUM SERIES

FKM / FPM SEAL BONNET 150°C¹

ACTUATOR	PORT FLANGE	FLANGE THREAD	BONNET SEAL	WEIGHT POUNDS	REFERENCE	PART NUMBER
MANUAL	DEL-SEAL	UNF	FKM/FPM	110	GV-10000V	300008
MANUAL	ISO	METRIC	FKM/FPM	105	LGV-10000V	306008
MANUAL	ASA	UNC	FKM/FPM	110	GV-10000V-ASA	304006
PNEUMATIC	DEL-SEAL	UNF	FKM/FPM	110	GV-10000V-P	301008
PNEUMATIC	ISO	METRIC	FKM/FPM	105	LGV-10000V-P	307008
PNEUMATIC	ASA	UNC	FKM/FPM	110	GV-10000V-ASA-P	305006

¹ See page 166 for detailed bakeout specification

VALVE OPTIONS



DESCRIPTION	OPTION NUMBER
MECHANICAL POSITION INDICATOR	-01
24 VDC AIR CONTROL SOLENOID VALVE	-03
240 VAC AIR CONTROL SOLENOID VALVE	-09
2" ROUGHING PORT	-06
KALREZ HIGH TEMP O-RING	-11

When ordering Gate Valve Options, please add the option number(s) to the end of the desired UHV or HV Series Gate Valve Part Number listed above. For example 303016-09
Detailed descriptions of each option begin on page 164.

ACCESSORIES

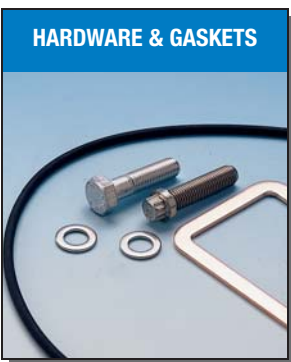

GASKET KIT	MATERIAL	QUANTITY PER PACK	REFERENCE	PART NUMBER
GATE & BONNET SEAL	FKM/FPM	1 ²	GVG-10000	354008
GATE & BONNET SEAL	FKM/FPM & COPPER	1 ²	GVG-10000M	355008

HARDWARE	THREAD LENGTH	FOR USE WITH	QUANTITY PER PACK	REFERENCE	PART NUMBER
HEX HEAD SET	.375-24 x 1-3/4"	DEL-SEAL	30	BA-1003-SP	190506
METRIC HEX HEAD SET	M10, 30mm LONG	ISO	25	M10-30-SP	190172
HEX HEAD SET	.750-10 x 1-3/4"	ASA	24	GVBA-1000-SP	190178

² Each gasket kit contains one Bonnet and one Gate seal

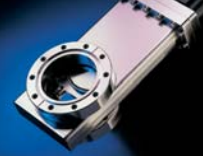

GV-12000M

GV-12000M-P

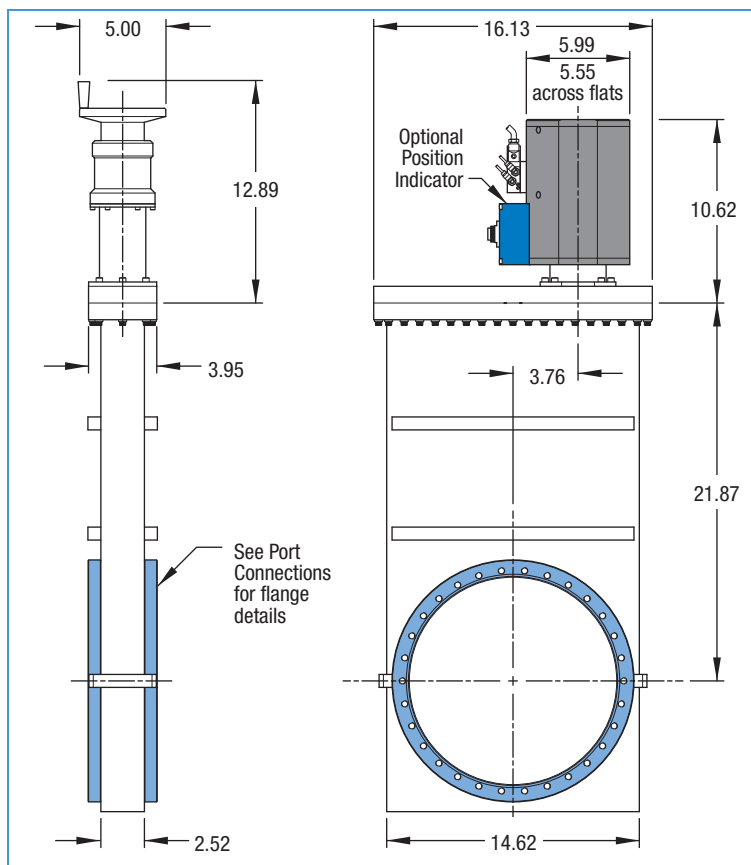

ULTRAHIGH VACUUM SERIES

250°C Metal Sealed Bonnets

HIGH VACUUM SERIES

150°C FKM / FPM fluoroelastomer O-Ring Sealed Bonnets

Features

- FKM / FPM fluoroelastomer O-Ring Sealed Gates
- Stainless Steel Construction
- Manual or Electropneumatic Operation

PORT CONNECTIONS

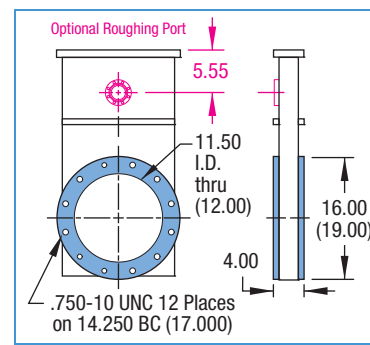
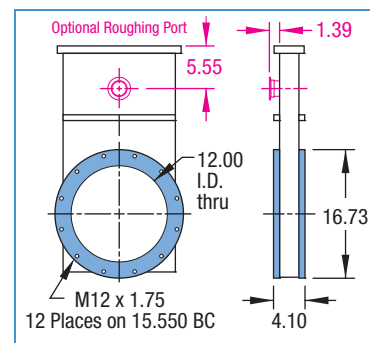
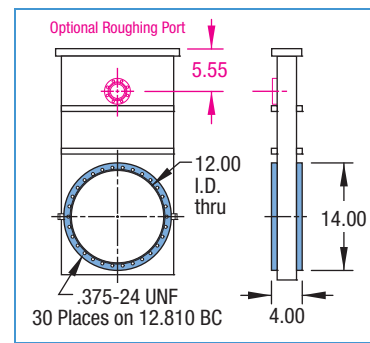



ULTRAHIGH VACUUM SERIES

METAL SEAL BONNET 250°C¹

ACTUATOR	PORT FLANGE	FLANGE THREAD	BONNET SEAL	WEIGHT POUNDS	REFERENCE	PART NUMBER
MANUAL	DEL-SEAL	UNF	METAL	153	GV-12000M	302009
PNEUMATIC	DEL-SEAL	UNF	METAL	153	GV-12000M-P	303009

HIGH VACUUM SERIES

FKM / FPM SEAL BONNET 150°C¹

ACTUATOR	PORT FLANGE	FLANGE THREAD	BONNET SEAL	WEIGHT POUNDS	REFERENCE	PART NUMBER
MANUAL	DEL-SEAL	UNF	FKM/FPM	153	GV-12000V	300009
MANUAL	ISO	METRIC	FKM/FPM	148	LGV-12000V	306009
MANUAL	ASA10	UNC	FKM/FPM	153	GV-12000V-ASA	304007
MANUAL	ASA12	UNC	FKM/FPM	200	GV-12001V-ASA	304008
PNEUMATIC	DEL-SEAL	UNF	FKM/FPM	153	GV-12000V-P	301009
PNEUMATIC	ISO	METRIC	FKM/FPM	148	LGV-12000V-P	307009
PNEUMATIC	ASA10	UNC	FKM/FPM	153	GV-12000V-ASA-P	305007
PNEUMATIC	ASA12	UNC	FKM/FPM	200	GV-12001V-ASA-P	305008

¹ See page 166 for detailed bakeout specification

VALVE OPTIONS



DESCRIPTION	OPTION NUMBER
MECHANICAL POSITION INDICATOR	-01
24 VDC AIR CONTROL SOLENOID VALVE	-03
240 VAC AIR CONTROL SOLENOID VALVE	-09
2" ROUGHING PORT	-06
KALREZ HIGH TEMP O-RING	-11

When ordering Gate Valve Options, please add the option number(s) to the end of the desired UHV or HV Series Gate Valve Part Number listed above. For example 303016-09
Detailed descriptions of each option begin on page 164.

ACCESSORIES

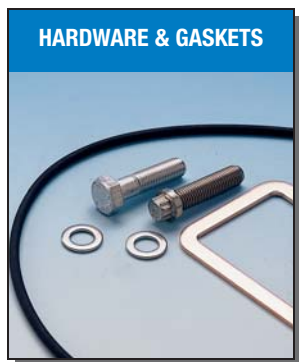

GASKET KIT	MATERIAL	QUANTITY PER PACK	REFERENCE	PART NUMBER
GATE & BONNET SEAL	FKM/FPM	1 ²	GVG-12000	354009
GATE & BONNET SEAL	FKM/FPM & COPPER	1 ²	GVG-12000M	355009

HARDWARE	THREAD LENGTH	FOR USE WITH	QUANTITY PER PACK	REFERENCE	PART NUMBER
HEX HEAD SET	.375-24 x 1-3/4"	DEL-SEAL	30	BA-1003-SP	190506
METRIC HEX HEAD SET	M12, 40mm LONG	ISO	25	M12-40-SP	190173
HEX HEAD SET	.750-10 x 1-3/4"	ASA	24	GVBA-1200-SP	190178

² Each gasket kit contains one Bonnet and one Gate seal



HIGH VACUUM SERIES
150°C FKM / FPM fluoroelastomer
O-Ring Sealed Bonnets

Features

- FKM / FPM fluoroelastomer O-Ring Sealed Gates
- Stainless Steel Construction
- Electropneumatic Operation
- Mechanical Position Indicator
- Patented Uni-Loc™ Locking Mechanism
- Double Impulse 24VDC Air Control Solenoid

SEMI short for 'Semiconductor Equipment & Materials International' developed the 'Modular Equipment Standards Committee', better known as MESC, to establish global interchangeability and modularity between products from the numerous sources in the semiconductor manufacturing equipment and components industry.

MDC LVHC series rectangular gate valves meet or exceed all applicable MESC standards. LVHC valves incorporate a patented one piece gate and carriage design that virtually eliminates vibration and particle generation. O-ring scuffing and wear are non-existent because of a floating driver bar design. The one piece gate and carriage can be removed through the valve's bonnet flange for gate seal replacement, cleaning, etc., without disassembling the valve body from the system.

LVHC valves are available in either 2.75" (70mm) or 1.97" (50mm) flange-to-flange thicknesses, with rectangular ports of 1.25 x 8.75" (32 x 222mm) or 1.81 x 9.30" (46 x 236mm) dimensions. These valves are designed for use in high vacuum load-lock systems used in semiconductor processing, where low vibration and low particle generation are imperative. The valves' low outgassing characteristics can be attributed to a fusion welded 300 series stainless steel body, welded AM-350 stainless steel nesting bellows as well as small cross section O-rings and the elimination of blind internal cavities. Custom design valves are available on request.

Pneumatic actuators are fitted with mechanical position indicators which indicate fully open and fully closed positions. This MPI system consists of two single pole, double throw micro switches fitted with integral hinged lever and roller actuators. Each micro switch is wired in a normally open position via a seven pin circular threaded connector. Mating female cable connectors are included.

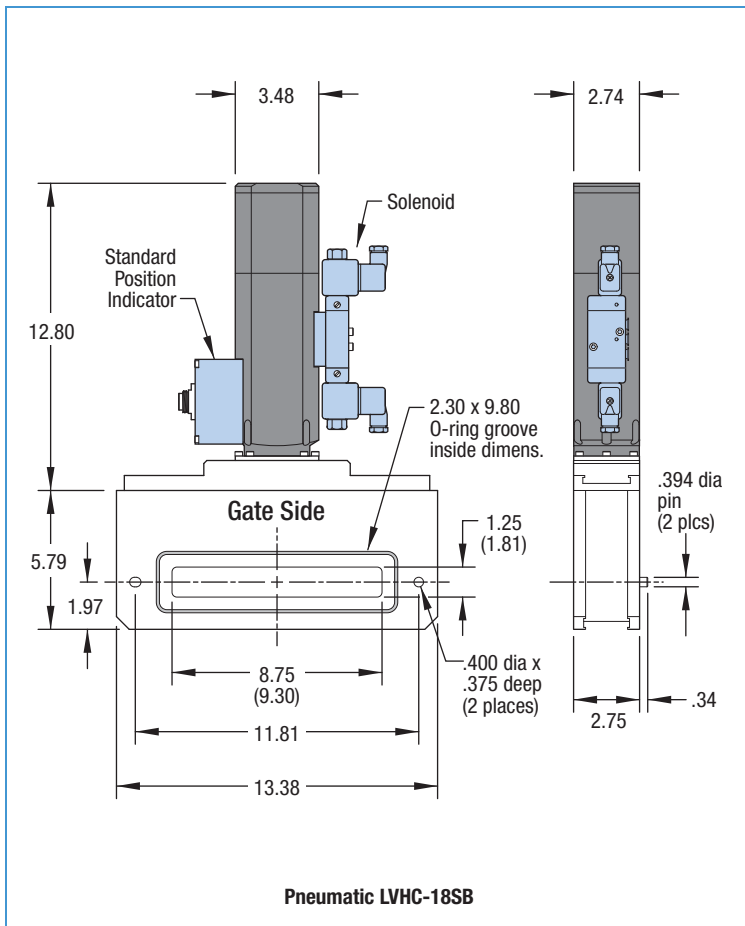

Normally closed switch wiring is available on request. Precise positioning of micro switches is made possible by a patented vernier adjustment mechanism only available on MDC gate valves.

Pneumatic actuators are equipped with dual impulse Herion 24 VDC air control solenoid valves. All solenoid valves are fitted with DIN type connectors that conform to international standards. DIN connectors provide simplicity, convenience and fast, easy electrical installation. Solenoid valves are designed for use with compressed air from 0 to 125psig. Air should be clean and uncontaminated. When in doubt, install a filter with filtering capacity of 40 microns. Periodically remove and clean or replace filter element.

Additional Features

- SEMI / MESC port flanges for use with claw type fasteners
- 1.25 x 8.75" (32 x 222mm) and 1.81 x 9.30" (46 x 236mm) inch rectangular port apertures
- 2.75" (70mm) or 1.97" (50mm) flange-to-flange body thickness
- FKM / FPM fluoroelastomer elastomer bonnet and gate seals
- Welded bellows actuator seal
- TIG welded internal body joints
- Electropolished interior and exterior surfaces
- Low vibration and particle generation
- Dry film lubricated bearings

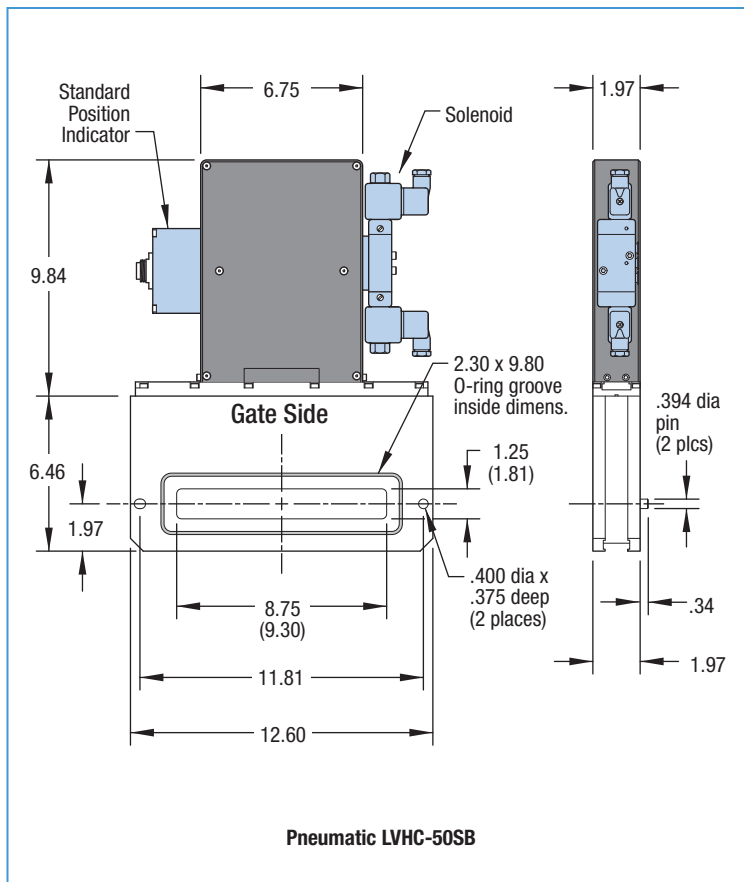

SEMI / MESC

HIGH VACUUM SERIES

FKM / FPM SEAL BONNET

150°C¹

ACTUATOR	PORT FLANGE	BONNET SEAL	WEIGHT POUNDS	REFERENCE	PART NUMBER
PNEUMATIC	1.25 x 8.75	FKM/FPM	41	LVHC-18SB	330001
PNEUMATIC	1.25 x 9.30	FKM/FPM	41	LVHC-18LB	330004
PNEUMATIC	1.81 x 8.75	FKM/FPM	41	LVHC-50SB	330005
PNEUMATIC	1.81 x 9.30	FKM/FPM	41	LVHC-50LB	330006

¹ See page 167 for detailed bakeout specification

ACCESSORIES

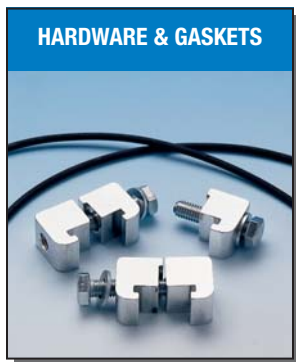

GASKET KIT	MATERIAL	QUANTITY PER PACK	REFERENCE	PART NUMBER
GATE & BONNET SEAL	FKM/FPM	1 ²	LVHCG-18-SB/LB	330101
GATE & BONNET SEAL	FKM/FPM	1 ²	LVHCG-50-SB/LB	330102
BODY FLANGE SEAL	FKM/FPM	2	LVHCG-1850B	330103

HARDWARE ³	THREAD LENGTH	FOR USE WITH	QUANTITY PER PACK	REFERENCE	PART NUMBER
SINGLE CLAW CLAMP KIT	M8, 35mm LONG	MESC	4	LVHC-SCK	801009
DOUBLE CLAW CLAMP KIT	M8, 35mm LONG	MESC	4	LVHC-DCK	802009

² Each gasket kit contains one Bonnet and one Gate seal

³ Recommended use of 8 to 12 clamps per side



HIGH VACUUM SERIES
150°C FKM / FPM fluoroelastomer
O-Ring Sealed Bonnets

Features

- FKM / FPM fluoroelastomer O-Ring Sealed Gates
- Stainless Steel Construction
- Manual or Electropneumatic Operation
- Mechanical Position Indicator
- Patented C-Loc® Locking Mechanism
- Double Impulse 24VDC Air Control Solenoid

RGV stainless steel vacuum gate valves incorporate patented C-Loc® gate valve locking technology. No contact is made between the valve body and the locking mechanism, a feature which markedly decreases vibration and insures smooth valve operation. RGV valves are designed for use in high vacuum load-lock systems used in semiconductor processing. Low outgassing characteristics can be attributed to fusion welded 300 series stainless steel body and AM-350 stainless steel nesting bellows, small cross-section O-rings and the elimination of blind internal cavities.

MDC RGV gate valves are offered in four standard sizes ranging from 1 x 6.3" (25 x 160mm) to 1 x 16.5" (25 x 420mm) rectangular port dimensions. Flange-to-flange body thickness is 2.75" (70mm). Gate valve actuators are available in both manual and electropneumatic configurations. The gate and carriage can be removed through the valve's bonnet flange for gate seal replacement, cleaning, etc., without disassembling the valve body from the system. Custom design valves are available on request.

Pneumatic actuators are fitted with mechanical position indicators which indicate fully open and fully closed positions. This MPI system consists of two single pole, double throw micro switches fitted with integral hinged lever and roller actuators.

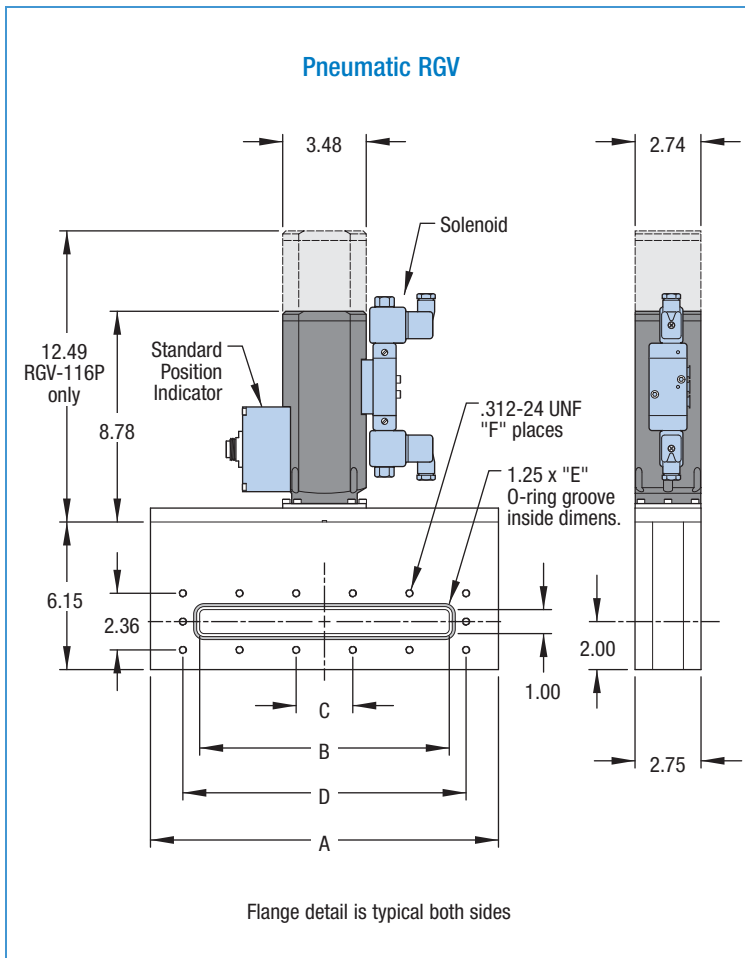

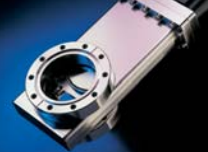

Each micro switch is wired in a normally open position via a seven pin circular threaded connector. Mating female cable connectors are included. Normally closed switch wiring is available on request. Precise positioning of micro switches is made possible by a patented vernier adjustment mechanism only available on MDC gate valves.

Pneumatic actuators are equipped with dual impulse Herion 24 VDC air control solenoid valves. All solenoid valves are fitted with DIN type connectors that conform to international standards. DIN connectors provide simplicity, convenience and fast, easy electrical installation. Solenoid valves are designed for use with compressed air from 0 to 125psig. Air should be clean and uncontaminated. When in doubt, install a filter with filtering capacity of 40 microns. Periodically remove and clean or replace filter element.

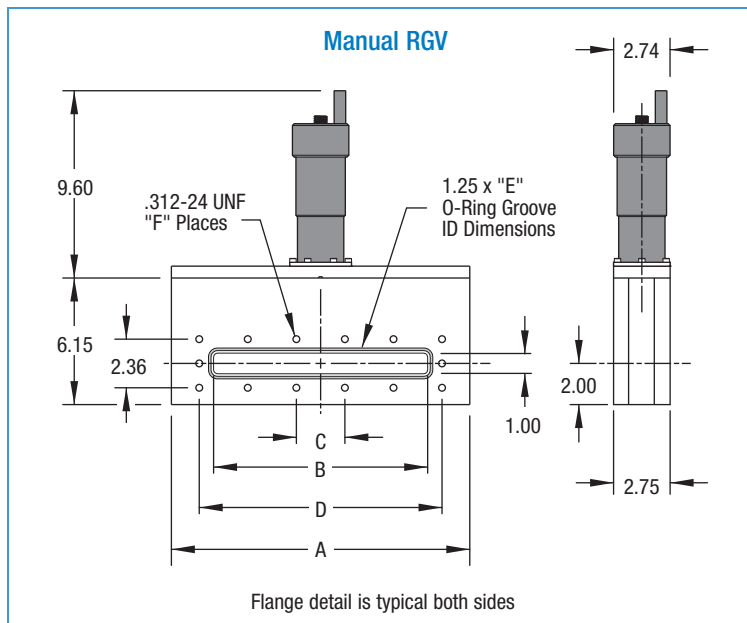

HIGH VACUUM SERIES 150°C¹

ACTUATOR	A	B	C	D	E	F	PORT ² FLANGE	BONNET SEAL	WEIGHT POUNDS	REFERENCE	PART NUMBER
MANUAL	10.50	6.30	2.75	8.25	6.75	10	1 x 6.3	FKM/FPM	60	RGV-16	331000
MANUAL	12.50	8.30	2.36	9.45	8.75	12	1 x 8.3	FKM/FPM	62	RGV-18	331002
MANUAL	14.50	10.40	2.36	11.80	10.65	14	1 x 10.4	FKM/FPM	65	RGV-110	331004
MANUAL	20.00	16.50	2.55	17.85	16.75	18	1 x 16.5	FKM/FPM	75	RGV-116	331013
PNEUMATIC	10.50	6.30	2.75	8.25	6.75	10	1 x 6.3	FKM/FPM	65	RGV-16P	331001
PNEUMATIC	12.50	8.30	2.36	9.45	8.75	12	1 x 8.3	FKM/FPM	68	RGV-18P	331003
PNEUMATIC	14.50	10.40	2.36	11.80	10.65	14	1 x 10.4	FKM/FPM	70	RGV-110P	331005
PNEUMATIC	20.00	16.50	2.55	17.85	16.75	18	1 x 16.5	FKM/FPM	80	RGV-116P	331014

¹ See page 167 for detailed bakeout specifications

² See method of connection, page 435

ACCESSORIES

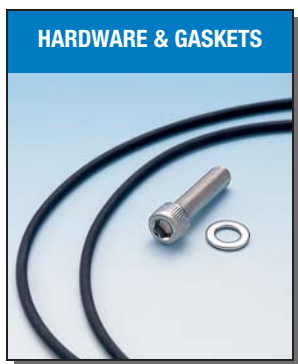

GASKET KIT		MATERIAL	QUANTITY PER PACK	REFERENCE	PART NUMBER
1 x 6.3	GATE & BONNET SEAL	FKM/FPM	1 ³	RGVG-16	331101
1 x 8.3	GATE & BONNET SEAL	FKM/FPM	1 ³	RGVG-18	331102
1 x 10.4	GATE & BONNET SEAL	FKM/FPM	1 ³	RGVG-110	331103
1 x 16.5	GATE & BONNET SEAL	FKM/FPM	1 ³	RGVG-116	331104
1 x 6.3	BODY FLANGE SEAL	FKM/FPM	2	RGVG-16B	331105
1 x 8.3	BODY FLANGE SEAL	FKM/FPM	2	RGVG-18B	331106
1 x 10.4	BODY FLANGE SEAL	FKM/FPM	2	RGVG-110B	331107
1 x 16.5	BODY FLANGE SEAL	FKM/FPM	2	RGVG-116B	331108

HARDWARE	THREAD LENGTH	FOR USE WITH	QUANTITY PER PACK	REFERENCE	PART NUMBER
SOCKET HEAD	.312-24 x 1"	RGV	24	BA-RGV-18	331012

³ Each gasket kit contains one Bonnet and one Gate seal

